

# Typical faults and safety analysis of brake controller for AC locomotive

Yujie Ren

*Brake Technology Development Department,  
Beijing Zongheng Electro-Mechanical Technology Co., Ltd, Beijing, China, and*

Hai Chi

*Locomotive and Car Research Institute,  
China Academy of Railway Sciences Corporation Limited, Beijing, China*

## Abstract

**Purpose** – The brake controller is a key component of the locomotive brake system. It is essential to study its safety.

**Design/methodology/approach** – This paper summarizes and analyzes typical faults of the brake controller, and proposes four categories of faults: position sensor faults, microswitch faults, mechanical faults and communication faults. Suggestions and methods for improving the safety of the brake controller are also presented.

**Findings** – In this paper, a self-judgment and self-learning dynamic calibration method is proposed, which integrates the linear error of the sensor and the manufacturing and assembly errors of the brake controller to solve the output drift. This paper also proposes a logic for diagnosing and handling microswitch faults. Suggestions are proposed for other faults of brake controller.

**Originality/value** – The methods proposed in this paper can greatly improve the usability of the brake controller and reduce the failure rate.

**Keywords** Locomotive brake system, Brake controller, Faults

**Paper type** Research paper

## 1. Introduction

Currently, railway transportation holds a crucial position in China's transportation industry. It not only provides convenient and high-quality services for both short and long-distance travel but also influences the lifeline of the national economy. Therefore, safety has always been a top priority. AC locomotives serve as a primary role in railway transportation, and ensuring the safety of brake is an essential component of overall railway safety work. Over the past few decades, China's AC locomotive brake control systems have undergone a path of independent innovation, starting from technical introduction, learning, imitation and then surpassing (Li & Yan, 2019). This process has effectively guaranteed the safety of locomotives. Presently, the commonly used locomotive brake control systems include CCB II, DK-2, JZ-8 and CAB *et al.* (Li & Wang, 2016). The brake controller for each braking system has experienced malfunctions for a variety of reasons, which have disrupted the normal order of railway transportation (Tu, 2017). The classification, safety analysis and countermeasures



for these malfunctions have significant positive implications for our future maintenance and research work.

The brake controller is a key component of the locomotive braking system and is a typical position controller. It is normally located on the left side of the locomotive driver's cab and equipped with the automatic brake handle and the independent brake handle (Li & Wang, 2012). The automatic brake handle has positions with locating slot from bottom to top including the running position, minimum brake position, full service position, suppression position, multiple-unit position and emergency brake position. The separate brake handle has running positions and full brake positions. By manipulating these two handles, different functions such as automatic braking, independent braking and emergency braking can be achieved. Locomotive brake control systems adopt a control architecture based on network data. Therefore, as one of the network nodes, the brake controller can generate control commands by the driver operating the automatic brake handle or independent brake handle, and send them to the electro-pneumatic control unit (EPCU), which is the executive component of the braking system. Additionally, the brake controller can monitor its own status in real-time and promptly report any abnormal conditions to the braking system. Based on practical applications, the faults of the brake controller can be classified into four categories. The first category is position sensor faults, which are related to the sensors that perceive the position of the operating handles. Due to being moving parts, the failure rate of position sensors is relatively high among brake controller faults. The second category is microswitch faults, which are typically used to confirm the handle's specific positions, such as the running position and emergency brake position. The third category is mechanical faults, such as handle sticking or changes of movement resistance. The fourth category is communication faults, including communication abnormalities and loss. In addition, there are occasional faults related to mechanical exhaust valves and wiring harnesses, which are often caused by non-standard manufacture and can be avoided by improving management. See Figure 1.

## 2. Position sensor faults

The majority of brake control systems use a potentiometer as the position sensor for the brake controller. The most typical one is CCB II from Knorr-Bremse Group, which has two potentiometers, AP and IP, inside its brake controller. Normally, the resistance value of the potentiometers must be within a safe range. If the resistance value falls below a specific threshold, error codes 075 and 076 will be reported (Li, 2010). Since the resistance value of the

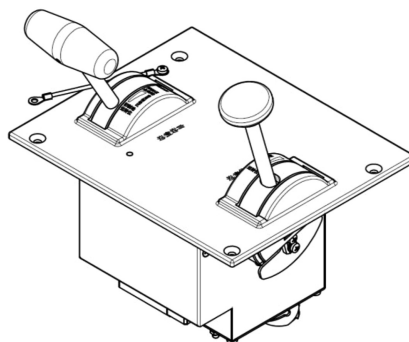

Source(s): Authors own work

Figure 1.  
The outline diagram of  
brake controller

potentiometers is influenced by external factors such as temperature and humidity, these types of faults occur quite frequently at certain times. The Daqin Railway Line locomotives experience many 075 and 076 faults during winter, requiring the maintenance department to calibrate the brake controllers every 7 days (Yang, Zhang, & Li, 2011). This imposes a significant amount of additional work on maintenance operations. The Jinan West maintenance depot has encountered abnormal voltage fluctuations in the output of the potentiometers. After analysis, it was found that the problem was caused by momentary poor contact of the potentiometer's contacts. When this fault occurs, it triggers automatic pressure reduction in the braking system and leads to train safety accident (Wang, 2019). The output of the position sensor is the source of signals for the brake controller, so any errors in the sensor's output are critical issues for the brake controller, posing a serious threat to the safety and stability of the braking system. Currently, the main faults are concentrated in the drift of the sensor's output, a decrease in linearity and wear aging of the sensor itself. It is common for sensors to gradually drift in their output as they are used. In addition to regular position calibration as done by the Daqin Line, optimization can also be performed in the application program to achieve dynamic calibration based on big data. This not only enables maintenance-free brake controllers but also replaces the two-point calibration of the brake controller's extreme positions with multi-point calibration for each position, improving the accuracy of the brake controller. The specific steps are shown in Figure 2.

After the initial calibration of the brake controller, a theoretical output value  $A$  can be calculated for a specific functional position (using full service position as an example). When the handle is set to the full service position, the actual output value  $B$  of the sensor can be obtained. For the full service position,  $A$  represents the theoretical value, while  $B$  represents the actual value, resulting in a certain difference between the two. The corresponding standard output for the full service position at this time is  $A$ . During the application process, each time the full service position is reached, an actual value  $B$  is obtained. With continued use, a series of actual values  $B_1, B_2, \dots, B_n$  will be obtained. Since the handle positions have mechanical locating slot, this series of  $B$  values will not deviate significantly and will exhibit a certain normal distribution pattern. When  $n$  reaches a certain value, such as 50, the average

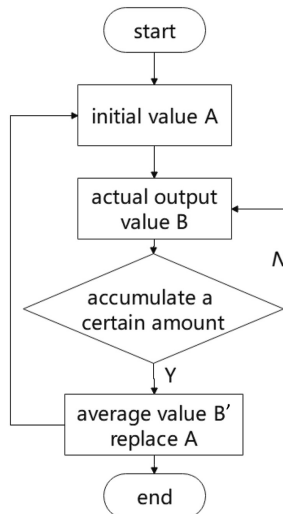

**Figure 2.**  
The flow chart of  
intelligent calibration

**Source(s):** Authors own work

value of B1 to B50 is taken, yielding a value B' that is more accurate for the current brake controller's output in the full brake position. B' is then used to replace A as the standard output for the full service position. By continuously iterating the standard values for each handle position, the influence of sensor drift can be eliminated. This approach offers benefits beyond that, as it also improves the brake controller's acceptance of non-linearity in the position sensor. Through automatic calibration for each position, the original linear calibration curve is transformed into a segmented piecewise line, greatly enhancing calibration accuracy. As a result, faults caused by calibration deviations, such as abrupt changes in the brake controller's position output, can be effectively avoided, thereby increasing the reliability of the brake controller.

In the laboratory, using the brake handle of the CAB brake system, calibrate the automatic brake handle according to the existing calibration logic to obtain the calibration curve of the sensor, as shown in the black curve in Figure 3. Only the running position and emergency brake position have calibration points, and other positions are calculated linearly based on the design dimensions. Then, the calibration program for the brake handle is renewed according to the logic shown in Figure 2. Then the brake handle is operated to move, and calibration will be done automatically for each position of the handle during the movement process. After all positions are calibrated, the red calibration curve in Figure 3 can be obtained. Each position corresponds to a standard output value. As can be seen from Figure 3, due to sensor errors, manufacturing errors and assembly errors, it is difficult to ensure that all positions are perfectly on a linear curve with the same brake handle and angle sensor. Therefore, intelligent calibration based on big data is very meaningful, as it can achieve actual state calibration that includes all errors, and can be adjusted in real time according to the brake handle state. It is an intelligent calibration method. At the same time, the calibration of each position is completely independent, and once a position is calibrated, the standard output value for that position is adjusted, maintaining real-time performance.

To address the problem of momentary poor contact in potentiometer, the use of non-contact position sensors can completely solve such issues. Currently, two mature solutions are commonly used: encoders and electromagnetic sensors. Encoders have a relatively large size and more complex structure, but they offer higher accuracy, stable output, high linearity and lower requirements for installation and application. However, encoders are relatively expensive. On the other hand, electromagnetic sensors have slightly lower

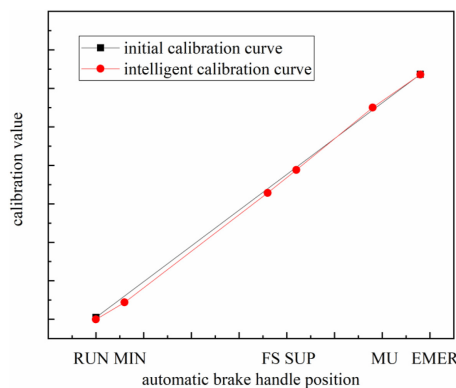

Source(s): Authors own work

Figure 3.  
The curves of initial  
calibration and  
intelligent calibration

accuracy, which is still sufficient for brake controller. They have good repeatability but slightly poorer linearity. They require high installation and application requirements due to the need to avoid the position state with an output of 0. However, electromagnetic sensors are cheaper, exhibit stable performance and have strong anti-interference ability in the surrounding environment. Both solutions are widely used in practical scenarios and are considered ideal alternatives to potentiometer solutions, thereby improving the safety of brake controllers.

### 3. Microswitch faults

Brake controllers of different brake control system incorporate microswitches as confirmation signals for extreme positions (Wei, Mao, & Liu, 2022). Therefore, there are at least four microswitches: automatic brake handle's running position, emergency position, separate brake handle's running position and full brake position. Also, an additional microswitch is usually installed to achieve release function. Although there are some differences in the logic of using sensors and microswitch signals among manufacturers, it is common that errors in microswitch signals have a significant impact on the brake system (Zhu, 2012). For example, if there is a failure in automatic brake handle's running position of CCB II, the train will be unable to release completely, while other positions will trigger a 077 fault alarm (Cheng, 2019). In the case of automatic brake handle of CAB, a short circuit in the microswitch for the emergency brake position will keep the brake system in the emergency brake state (Ren, Zha, Li, Ye, & Lin, 2016). Some of these failures are due to incorrect direction of wire harness welding during the production process, causing rosin to remain on the switch contact and resulting in intermittent poor contact (Liu & Tian, 2019). Others are caused by condensation from air conditioning outlets entering the relevant brake connectors during the high-temperature period of summer, interfering with the normal operation of the brake controller (Chen, 2015). There are also rare cases where repeated actions of the microswitch lead to internal spring breakage, rendering it unable to reset after completing an action. While the causes of these problems are diverse, in addition to improving manufacturing processes and strengthening maintenance, optimization of control logic should also be emphasized.

The standards of brake controller and brake system do not specify the logical coordination between position sensors and position microswitches. Both can provide the handle position of brake controller. Different manufacturers have different approaches when the two signals indicate different positions. This poses a significant risk to the safety application of the brake system and is not conducive to fault diagnosis and troubleshooting in practical scenarios. Therefore, it is necessary to establish unified rules. Release microswitch of separate handle is relatively straightforward. In the case of an open circuit, there is no separate release function, while for a short circuit, the signal can be ignored after a certain period (e.g. two minutes). The microswitch signals and sensor output for the running position and the full brake position of the separate handle should be combined using the logical OR. An open circuit in the microswitch has no impact on the system, and the actual position of the handle should be determined based on the sensor output. If there is a short circuit in the full brake position microswitch, the full brake position microswitch signal can be ignored once the sensor and running position switch signals have been confirmed. Before confirmation, it should be treated as if in the full brake position. The same applies to a short circuit in the running position switch. After confirming the sensor and full brake position switch signals once, the running position switch signal can be ignored. Before confirmation, it should be treated as if in the running position. The microswitch for the emergency brake position of the automatic brake handle should be combined with the sensor signal using the logical OR

operation. In the case of an open circuit in the microswitch, the signal can be ignored without any impact. In the case of a short circuit, the brake system should remain in the emergency brake state until the sensor and running position switch signals have been confirmed. At that point, the microswitch signal for the emergency brake position can be ignored. The microswitch signals for the running position of the automatic brake handle and the sensor signals should be combined using the logical AND operation. This is done for safety reasons, so that in the event of a short circuit in the running position microswitch, the normal functionality of the brake controller is not affected. In the case of an open circuit in the position microswitch, if the position sensor detects that it is in the running position, the minimum brake command will be issued until the sensor and microswitch signals of emergency brake position are confirmed. At that point, the running position microswitch signal can be ignored, and the handle position should be determined based on the sensor signal. The overall approach aims to ensure that the failure of a single microswitch signal does not render the brake system irreversibly locked, leading to equipment damage. However, before ignoring the microswitch signal, the sensor signal at the other extreme position should be confirmed, ensuring that the sensor signal is normal. Temporary operation should then be maintained based on the sensor signal. It is important to note that the microswitch signals for both extreme positions of the same handle should not be ignored. Faults and the ignorance of microswitch signals should be indicated on the locomotive cab display, and the brake controller should be replaced as soon as possible after returning to the depot.

#### 4. Mechanical faults

Mechanical failures of the brake controller have occurred during application. After half a year of operation, the brake controller of CCB II at Zhengzhou Railway Depot exhibited small resistance for both handles, directly affecting the normal operation for the drivers (Zhu, 2012). The CAB brake control system has also experienced instances where it remained in the released position without the ability to return. Additionally, incidents have been reported at Urumqi Railway Depot where the automatic brake handle of the brake controller slipped from the brake zone to the running position, and at Shenyang Railway Depot where the brake handle rebounded to the minimum brake position. These issues have been analyzed and found to be caused by mechanical defect of the handles, some due to unreasonable manufacturing processes and others due to design flaws. Mechanical failures have obvious temporal characteristics, mainly occurring more frequently during the initial use of new products. For example, the looseness of the brake controller handles is caused by loose screws due to improper assembly. The handle slipping and rebounding are also caused by the poor design of the fixing screws. While mechanical failures have a significant impact on safety, they do not have the occasional and unpredictable nature of electronic device failures. Generally, after rectification, mechanical failures can be completely avoided. As the usage time increases, the design will become more refined, and the production process will become more reasonable, resulting in lower rates of mechanical failures. At present, mature brake products no longer have mechanical failures as the primary issue with the brake controller. As experience accumulates with new products, the occurrence of mechanical failures will decrease (Peng, Lin, & Xu, 2012). Nevertheless, manufacturers still need to pursue excellence in design and production processes and cannot become complacent. Otherwise, many minor errors can lead to serious consequences.

Due to the numerous electronic components inside the brake handle, the wiring harness has to traverse through the interior of the handle structure. These wire harnesses must be securely fastened in specific locations to prevent wear and tear by moving parts inside the handle. In one case, brake controller wiring harness had worn out by

transmission gears and eventually resulted in a short circuit, causing the penalty brake. In another case, production process of the brake control is also very important. As is well known, metal movement requires grease to lubricate, and the movement of the brake handle cannot be achieved without the function of grease. However, sometimes, grease plays a counterproductive role. When the running distance is limited and the clearance is small, too much grease not only cannot play the role of lubrication, but also has a similar effect as glue, adsorbing the parts together and losing their moving ability. Especially, after being left still for a period of time, this phenomenon is even more evident. The common cause of separate release function failure is precisely due to this reason. This requires strict control of the amount of grease used during the manufacturing process, applying an appropriate amount of grease to the appropriate places to ensure the available of the handle's function.

Therefore, mechanical failures of the brake controller can be fundamentally avoided, but it requires manufacturing companies to approach the task with reverence, caution, careful consideration and enthusiasm in order to achieve a perfect product (Gong, 2007).

### 5. Communication faults

The brake controller is a node in the brake system network, and its communication with other components of the brake system relies on network messages. If there is an abnormal or lost communication between the brake controller and other components, the brake system cannot receive proper control signals. This is fatal for the brake system as it loses the main channel of interpreting the driver's braking or releasing intentions (Zhang, 2018). There are various causes for communication failures, but currently, brake systems respond to this situation by applying penalty brake. This fault is one of the class A brake system faults, which can have a significant impact on the safety of railway transportation.

Currently, there are two main approaches to address the communication failure of the brake handle, which includes software and hardware solutions. In terms of software, the priority of the brake handle is set to the highest within the brake system's intranet. For example, in the controller area network (CAN) network, the lower the ID of a network node, the higher its priority. Therefore, the ID of the brake handle, as a CAN network node, is the smallest among all network nodes. This ensures that the network messages of the handle are prioritized for transmission in the event of network message collision errors. This feature is crucial in the design of the brake system's network architecture. Additionally, software monitoring functions are implemented internally in the brake handle software to reset the communication function immediately upon occurrence of network message transmission failure. In terms of hardware design, the control section of the brake handle is designed with dual-redundant power supply to ensure its reliability. Additionally, the network transmission is carried out through independent dual networks simultaneously transmitting the same messages, maximizing the possibility of delivering the handle commands to other network nodes of the brake system.

In most train models, even if the connection between the brake handle and the brake system is completely severed, the train can still be controlled by another mechanical handle, known as the pneumatic backup brake. It has three positions: the brake position, the holding position and the release position. When the handle is in the brake position, the pressure in the brake pipe continuously decreases. When the handle is in the release position, the pressure in the brake pipe continuously increases. The holding position maintains the pressure in the brake pipe unchanged. Through this design, a temporary remedy is provided for the brake handle communication loss, greatly improving the system's availability.

## 6. Conclusion

Through the classification and safety analysis of typical faults in the brake controller of brake control system, recommendations and methods for enhancing the safety of the brake controller are proposed. For position sensor related faults, two approaches are suggested. Firstly, the use of non-contact sensors such as potentiometer or electromagnetic sensors can help avoid occasional faults caused by poor contact. Secondly, a self-judging and self-learning dynamic calibration method is proposed. This method combines the linear error of the sensor with manufacturing and assembly errors of the brake controller to address faults resulting from sensor drift. Regarding microswitch faults, it is observed that such faults may not necessarily impact the normal operation of the brake controller. To improve the availability of the brake controller, a set of diagnostic and handling logic is proposed based on the ability to judge microswitch faults. Mechanical faults can be prevented and controlled through enhanced management of the design and production processes to minimize their occurrence. Communication faults in the brake controller are addressed uniquely in the some brake system. This system features a pneumatic backup brake, enabling control switching with another temporary replacement handle in the event of a communication fault in the brake controller. This substantially enhances the redundancy of the brake controller and improves the availability of the brake system. The brake controller, as a critical component within the brake system, demands unquestionable safety standards. Continuous in-depth analysis, innovation, optimization and iteration of its mechanical structure and control logic are essential to enhance the operational safety of the brake control system. This, in turn, provides robust assurance for the safety and orderliness of rail transportation.

## References

- Chen, Z. (2015). Discussion on working principle and fault analysis of CCBII brake and EBV. *Railway Locomotive & Car*, 35(3), 77–79.
- Cheng, H. (2019). The analysis and approach of fail code 077 for EBV of HX electric locomotive. *Railway Locomotive and Motor Car*, 547(9), 45–48.
- Gong, X. (2007). Analysis of assembly process of new electronic brake controller for locomotives. *Electric Locomotives & Mass Transit Vehicles*, 30(2), 49–50.
- Li, F. (2010). Design of fault detection and automatic switching device for brake valve of CCBII brake mechanism. *Taiyuan Railway Science and Technology*, 2, 30–32.
- Li, C., & Wang, J. (2012). Driver brake controller for HX<sub>D</sub>2 and HX<sub>D</sub>2B type locomotive. *Electric Drive for Locomotives*, 1, 33–36.
- Li, H., & Wang, S. (2016). Application and research of JZ-8 braking system. *Sci-tech Innovation and Productivity*, 269(6), 86–88.
- Li, H., & Yan, X. (2019). Development history of rolling stock brake technology of China railway in the past 70 years. *Railway Locomotive & Car*, 39(5), 25–35.
- Liu, B., & Tian, P. (2019). Fault analysis and improvement of brake controller action switch for EMU. *Electric Locomotives & Mass Transit Vehicles*, 42(4), 42–47.
- Peng, C., Lin, P., & Xu, Q. (2012). Improvement of structure design on brake controller. *Electric Locomotives & Mass Transit Vehicles*, 35(6), 34–36.
- Ren, Y., Zha, G., Li, W., Ye, B., & Lin, H. (2016). The duty reappearance and fault diagnosis of CAB based on virtualization technology. *Railway Locomotive & Car*, 36(5), 69–73.
- Tu, X. (2017). Control principle and fault analysis judgment of electronic brake valve (EBV) DK-2 brake in HX<sub>D</sub>1 locomotive. *Railway Locomotive & Car*, 37(6), 85–88.
- Wang, W. (2019). Cause analysis and corrective measures of HX<sub>D</sub>3 electric locomotive EBV typical failure. *Railway Locomotive and Motor Car*, 545(7), 37–39.

- Wei, C., Mao, J., & Liu, J. (2022). Fault detection and safety orientation for AC drive locomotive braking controller. *Mechanical and Electrical Information*, 683(11), 69–75.
- Yang, Y., Zhang, T., & Li, S. (2011). Working principle analysis and maintenance application for EBV of locomotive. *Electric Drive for Locomotives*, 6, 79–82.
- Zhang, J. (2018). Analysis and measures for the failure of CCBII brake EBV without pressure relief. *Taiyuan Railway Science and Technology*, 2, 14–16.
- Zhu, Y. (2012). Analysis and suggestions of EBV malfunction for CCBII brake of HX electric locomotive. *Railway Locomotive & Car*, 32(5), 55–57.

**Corresponding author**

Hai Chi can be contacted at: [chihai@zemt.cn](mailto:chihai@zemt.cn)