

# Scheme of long distance power supply for electrified railway traction network based on traction cable

Hui Wang, Qunzhan Li, Wei Liu, Chuang Wang and Tongtong Liu  
*School of Electrical Engineering, Southwest Jiaotong University, Chengdu, China*

## Abstract

**Purpose** – The traction cable is paralleled with the existing traction network of electrified railway through transverse connecting line to form the scheme of long distance power supply for the traction network. This paper aims to study the scheme composition and power supply distance (PSD) of the scheme.

**Design/methodology/approach** – Based on the structure of parallel traction network (referred to as “cable traction network (CTN)”), the power supply modes (PSMs) are divided into cable + direct PSM and cable + autotransformer (AT) PSM (including Japanese mode, French mode and new mode). Taking cable + Japanese AT PSM as an example, the scheme of long distance power supply for CTN under the PSMs of co-phase and out-of-phase power supply are designed. On the basis of establishing the equivalent circuit model and the chain circuit model of CTN, taking the train working voltage as the constraint condition, and based on the power flow calculation of multiple train loads, the calculation formula and process for determining the PSD of CTN are given. The impedance and PSD of CTN under the cable + AT PSM are simulated and analyzed, and a certain line is taken as an example to compare the scheme design.

**Findings** – Results show that the equivalent impedance of CTN under the cable + AT PSM is smaller, and the PSD is about 2.5 times of that under the AT PSM, which can effectively increase the PSD and the flexibility of external power supply location.

**Originality/value** – The research content can effectively improve the PSD of traction power supply system and has important reference value for the engineering application of the scheme.

**Keywords** Traction cable, Electrified railway, Traction network, Long distance power supply, Voltage drop, Power flow calculation

**Paper type** Research paper

## 1. Introduction

Urban railways have the characteristics of short inter-station distance, high proportion of regenerative braking energy and difficulty in location selection. Nowadays, traction power supply systems of urban railways are mostly designed with reference to power supply mode (PSM) of trunk railways (Li & He, 2012; Liu, Liu, Wang, Wang, & Li, 2019). On heavy haul railways, locomotives are high-power traction loads, and some lines see trains going down a slope with heavy load but going up a slope with light load and making little use of regenerative braking energy. Although a series of beneficial measures have been taken to improve the transport capacity, there are still some shortcomings (Zhou, 2020; Wu, 2016). The plateau electrified railway, represented by the Qinghai-Tibet Railway and Sichuan-Tibet

---

© Hui Wang, Qunzhan Li, Wei Liu, Chuang Wang and Tongtong Liu. Published in *Railway Sciences*. Published by Emerald Publishing Limited. This article is published under the Creative Commons Attribution (CC BY 4.0) licence. Anyone may reproduce, distribute, translate and create derivative works of this article (for both commercial and non-commercial purposes), subject to full attribution to the original publication and authors. The full terms of this licence may be seen at <http://creativecommons.org/licences/by/4.0/legalcode>

**Funding:** The research is funded by Youth Science Foundation Fund Project of National Natural Science Foundation of China (51607148); Science and Technology R&D Program of China State Railway Group Co., Ltd. (SY2020G001); Project of Sichuan Science and Technology Program (2021YJ0028)



Railway, faces lots of problems, such as weak external power supply, high proportion of bridges and tunnels, a large number of steep grades and inappropriateness of setting excessive neutral sections (Wang, Li, Li, Xie, & Huang, 2020a). Existing traction power supply system (TPSS) faces higher requirements and challenges on the basis of the above situation, such as decreased number of neutral sections in lines and more flexible location selection of the traction substation (TS), so that long distance power supply can be achieved on the premise of meeting the power supply capacity and being safe and reliable.

The voltage loss of the traction transformer and traction network (TN) constitutes the voltage loss of the TPSS, which is one of the important indicators to measure the power supply capacity and distance of the TPSS. Smaller voltage loss of the TPSS proves longer power supply distance (PSD) of the TN. The most direct way to see less voltage loss of the traction transformer is to increase busbar voltage on the traction side. Alternatively, both installation of energy-saving transformer and provision of the compensation device at the traction port of the traction transformer are acceptable. Measures to see less voltage loss of the TN include selection of cables with smaller impedance for the TN, provision of compensation device and improvement of PSMs and power factors. The TN, employing existing autotransformer (AT) PSM and other PSMs, can see less voltage loss and longer PSD by taking measures, such as addition of reinforced conductors and employment of full parallel connection in up and down direction traffic of double-track railways. The objective of seeing longer PSD and decreased number of neutral sections of the TN can also be achieved by using new technologies and new PSMs. A traction power supply scheme suitable for urban railways, where static var generators (SVGs) are installed in the TS and TN on the basis of the conventional PSM of the TN, is studied (Liu *et al.*, 2019). Wang *et al.* (2020a) study an interconnected power supply system with TS group, which can realize interconnected power supply provided that external power supplies form a tree structure to supply power. Li (2014) states that the co-phase compensation device can be installed in TS in replacement of neutral section at the exit of the substation and that the former Soviet Union and other countries adopt two-way feeding to supply power to a longer distance, and neutral section at the section post can be removed, but there is circulating current problem. Li (2015) proposes an interconnected power supply system with traction cables, which is of two-level PSM by the traction cable and TN. The traction cable and TN are connected through a single-phase transformer. Chen *et al.* (2019) study a co-phase interconnected power supply system, where failure of external power supplies to form a tress structural would cause circulating current. In this case, measures shall be taken to suppress circulating current. Hartmut *et al.* (2019) introduce a TPSS with 16.7 Hz system, which can realize interconnected power supply, but costs much and is only used in Germany, Sweden and other countries.

For the above PSMs, longer PSD of the TN can also be seen by decreasing the impedance of the TN. The effective way is to make parallel connection of the traction cable (referred to as “cable”) and existing TN through transverse connecting lines to form the scheme of long distance power supply for electrified railway TN based on traction cable (referred to as “cable traction network (CTN)”). This paper focuses on the current distribution, equivalent impedance and other electrical characteristics under three cable + AT PSMs; the power flow calculation model of load for multiple trains was built. Based on this model, the method of determining the PSD of the CTN was proposed, with the train working voltage as the constraint condition. The effectiveness and superiority of the scheme were illustrated by comparing electrical characteristics and making practical calculations.

## 2. Scheme of long distance power supply for CTN

Now there are mainly two PSMs for electrified railways in China, namely, direct PSM and AT PSM, among which the latter is divided into Japanese mode, French mode and new mode

(Wang, 2017; Li, 2010). They are distinguished by different connection modes of AT transformer in the first AT section near the TS. Therefore, in the scheme of long distance power supply for CTN, the power supply can be divided into cable + direct PSM and cable + AT PSM. Under this PSM, the traction cable can be a two-core cable or a combination of two single-phase cables. The following studies the scheme adopting complex cable + AT PSM by taking two-core cable as an example.

According to different AT PSMs, cable + AT PSMs are divided into cable + Japanese AT PSM, cable + French AT PSM and cable + new AT PSM. When three cable + AT PSMs are analyzed, the cable + AT PSM is analyzed by taking the cable + Japanese AT PSM as an example, with co-phase and out-of-phase PSMs shown in Figure 1, where  $T, R$  and  $C$  are OCS, rail and negative feeder, respectively,  $S_{L1}, S_{R1}, S_{R2}, AT_{L1}, AT_{R1}$  and  $AT_{R2}$  are numbers of AT posts and numbers of their transformers, respectively. AT transformer is installed in TS, TC and NC, and  $TC_1$  and  $NC_1$  are mutually standby traction cables in two loops. They are connected with AT TN at regular intervals through transverse connecting lines to form the CTN. When TC and NC in a loop fail,  $TC_1$  and  $NC_1$  in the other loops are put into operation to make the system more reliable and maintainable.

In the case that the negative sequence exceeds the standard, the PSM in Figure 1a can be the combination of the technical scheme of co-phase power supply (Li, 2014) with the technical scheme of SVG-based negative sequence compensation (Wang, Li, Li, Xie, & Huang, 2020b),

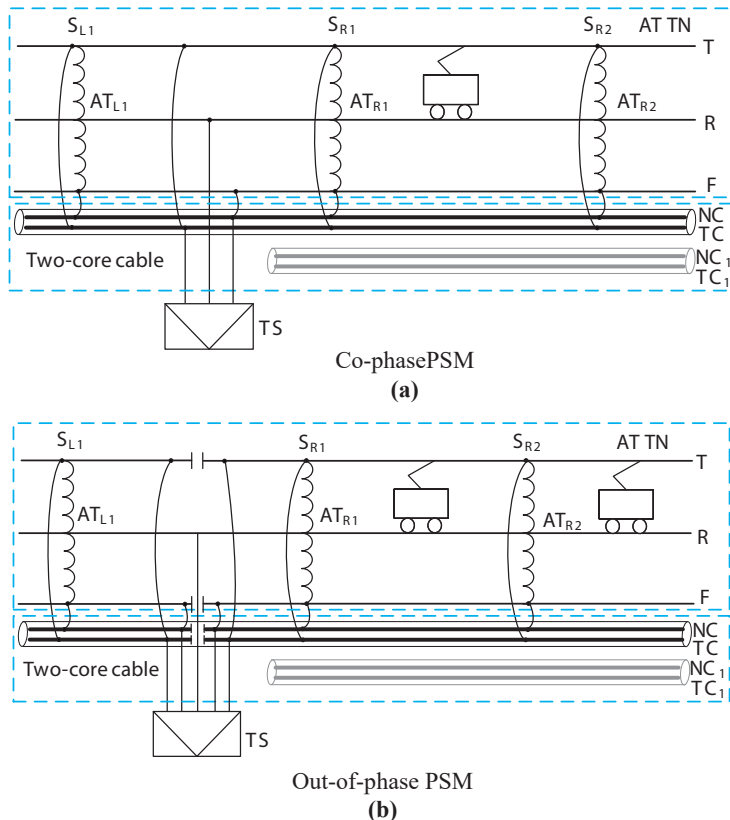

**Figure 1.**  
Cable + Japanese  
AT PSM

and the PSM in Figure 1b can be the technical scheme of SVG-based negative sequence compensation and the technical scheme of compensation with railway power transfer device.

### 3. Mathematical model of CTN

#### 3.1 Equivalent circuit model

By taking the right feeding section in Figure 1 as an example, both can be described as equivalent circuits as shown in Figure 2. The mutual impedance between AT TN and two-core cable can be ignored as two-core cable has the same current magnitude but opposite phase.

In Figure 2, the loop composed of AT transformers in front and at the rear of the train and CTN between transformers is defined as the short loop, while the loop from TS exit to the AT transformer near TS exit in the short loop where the train is located is defined as the long loop. In the figure:  $I_{c1}, I_{c3}, I_{c4}$  and  $I_{c5}$  are current phasors flowing in T, F, TC and NC lines of the long loop, respectively;  $I_{T1}, I_{T2}, I_{R1}, I_{R2}, I_F, I_{TC}$  and  $I_{NC}$  are current phasors flowing in lines of the short loop, respectively;  $U$  and  $I$  are, respectively, voltage and current phasors at both ends of the train;  $d_x$  is the distance between the AT transformer near TS exit in the short loop and the train;  $d_0$  is the distance between two AT transformers in the short loop;  $d_L$  is the distance from the train to TS exit;  $2U_0$  is the voltage between TC and NC at TS exit.

By analyzing the situation where there is only one train in the CTN, the current phasor equation of nodes 1–4 in Figure 2 can be obtained as follows:

$$I_{T1} + I_{TC} = 0.5I + 0.5I_{R1}. \quad (1)$$

$$I_{T2} = I_{TC} + 0.5I_{R2} \quad (2)$$

$$I_{R1} + I_{R2} = I \quad (3)$$

$$I_F + I_{NC} = 0.5I_{R2} \quad (4)$$

In upper and lower winding loops of AT transformer in AT section where the train is located, voltage drops  $\Delta U$  and  $\Delta U'$  are, respectively, as follows:

$$\Delta U = (Z_1 - Z_{21})[d_x I_{T1} - (d_0 - d_x)I_{T2}] + (Z_2 - Z_{12})[d_x I_{R1} - (d_0 - d_x)I_{R2}] + (Z_{23} - Z_{13})d_0 I_F \quad (5)$$

$$\Delta U' = (Z_{32} - Z_2)[d_x I_{R1} - (d_0 - d_x)I_{R2}] + (Z_{21} - Z_{31})[d_x I_{T1} - (d_0 - d_x)I_{T2}] + (Z_3 - Z_{23})d_0 I_F \quad (6)$$

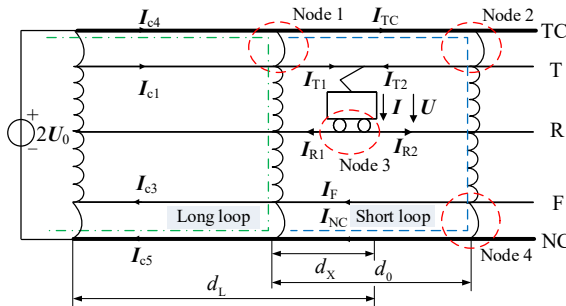

**Figure 2.**  
Equivalent circuit under cable + Japanese AT PSM

Where  $Z_1$ ,  $Z_2$  and  $Z_3$  are self-impedances per unit length of  $T$ ,  $R$  and  $F$  lines of CTN, respectively,  $Z_{12}$  ( $Z_{21}$ ),  $Z_{13}$  ( $Z_{31}$ ) and  $Z_{23}$  ( $Z_{32}$ ) are mutual impedances per unit length between  $T$ ,  $R$  and  $F$  lines of CTN, respectively.

$I_{R1}$ ,  $I_{R2}$ ,  $I_{T1}$ ,  $I_{T2}$ ,  $I_F$ ,  $I_{TC}$  and  $I_{NC}$  are evaluated respectively by combining (1)–(6).

$$I_{R1} = \left(1 - \frac{d_X}{d_0}\right) I \quad (7)$$

$$I_{R2} = \frac{d_X}{d_0} I \quad (8)$$

$$I_{T1} = I - \frac{1}{2} \frac{d_X}{d_0} (1 + k_1) I \quad (9)$$

$$I_{T2} = \frac{1}{2} \frac{d_X}{d_0} (1 + k_1) I \quad (10)$$

$$I_F = \frac{1}{2} \frac{d_X}{d_0} (1 - k_1) I \quad (11)$$

$$I_{TC} = I_{NC} = \frac{1}{2} k_1 \frac{d_X}{d_0} I \quad (12)$$

In which  $k_1 = \frac{Z_1 + Z_3 - 2Z_{13}}{Z_1 + Z_3 + 2Z_4 - 2Z_{45} - 2Z_{13}}$ .

Where  $Z_4$  and  $Z_5$  are self-impedances per unit length of TC and NC lines of CTN, respectively,  $Z_{45}$  is mutual impedance per unit length between TC and NC lines of CTN.

The equivalent circuit in the first AT section under cable + French AT PSM and cable + new AT PSM is shown in Figure 3, and that in other AT sections are the same as that under cable + Japanese AT PSM.

It is analyzed that current distribution in the first AT section under cable + French AT PSM as shown in Figure 3a is identical to that under cable + Japanese AT PSM, so line current in AT section is also identical; however, line currents  $I'_R$ ,  $I'_{TC}$ ,  $I'_{NC}$ ,  $I'_{T1}$ ,  $I'_{T2}$  and  $I'_F$  in the first AT section under cable + new AT PSM are, respectively, as follows:

$$I'_R = I \quad (13)$$

$$I'_{TC} = I'_{NC} = \frac{1}{2} k_1 \frac{d_{X1}}{d_1} I \quad (14)$$

$$I'_{T1} = \frac{1}{2} I - \frac{1}{2} k_1 \frac{d_{X1}}{d_1} I. \quad (15)$$

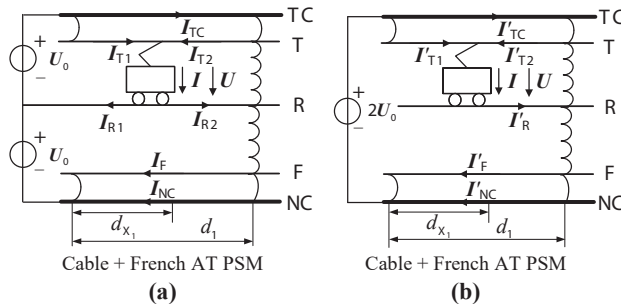

**Figure 3.**  
Equivalent circuit in  
first AT section under  
cable + AT PSM

$$\mathbf{I}'_{T2} = \frac{1}{2}\mathbf{I} + \frac{1}{2}k_1\frac{d_{X1}}{d_1}\mathbf{I}. \quad (16) \quad \text{Long distance power supply}$$

$$\mathbf{I}'_F = \frac{1}{2}\mathbf{I} - \frac{1}{2}k_1\frac{d_{X1}}{d_1}\mathbf{I}. \quad (17)$$

Where  $d_{x1}$  and  $d_1$  are, respectively,  $d_X$  and  $d_0$  when the train is located in the first AT section.

Under three cable + AT PSMs, the voltage drop  $\Delta U_1$  from TS exit to train is as follows

$$\Delta U_1 = U_0 - U = \frac{1}{2}U_{d_{L,A}} + U_{d_{L,B}}. \quad (18)$$

Where  $U_{d_{L,A}}$  and  $U_{d_{L,B}}$  are, respectively, voltage drops of long and short loops.

Under cable + Japanese PSM, voltage equations are, respectively, listed for loops made by  $T$  and  $F$  lines and TC and NC lines in the long loop in Figure 2, so that two expressions of  $U_{d_{L,A}}$  are obtained as follows

$$U_{d_{L,A}} = (Z_1 - Z_{31})(d_L - d_X)\mathbf{I}_{c1} + (Z_3 - Z_{13})(d_L - d_X)\mathbf{I}_{c3}. \quad (19)$$

$$U_{d_{L,A}} = (Z_4 - Z_{45})(d_L - d_X)(\mathbf{I}_{c4} + \mathbf{I}_{c5}) \quad (20)$$

Where  $\mathbf{I}_{c1} + \mathbf{I}_{c4} = \mathbf{I}_{c3} + \mathbf{I}_{c5} = 0.5\mathbf{I}$

On the basis of the voltage equation of the loop made by  $T$  line and rail  $R$ ,  $U_{d_{L,B}}$  is obtained as follows

$$U_{d_{L,B}} = (Z_1 - Z_{12})d_X\mathbf{I}_{T1} + (Z_{32} - Z_{31})d_X\mathbf{I}_F + (Z_2 - Z_{32})d_X\mathbf{I}_{R1} \quad (21)$$

The impedance  $Z$  of CTN under single cable + AT PSM is obtained as follows by combining Equations (18)–(21):

$$Z = \frac{\Delta U_1}{\mathbf{I}} = Z_A d_L + Z_B \left(1 - \frac{d_X}{d_0}\right) d_X \quad (22)$$

Where  $Z_A = \frac{1}{4}(1 - k_1)(Z_1 - 2Z_{31} + Z_3)$ ,  $Z_B = \frac{k_1}{1 - k_1}Z_A + \frac{1}{2}(Z_1 - Z_{32} + Z_{31} + 2Z_2 - 3Z_{12})$ .

Similarly, the impedance  $Z$  under cable + French AT PSM is identical to that under cable + Japanese AT PSM. The impedance  $Z'$  of CTN under cable + new AT PSM is shown in (23), except in the first AT section, and the impedance  $Z$  in other AT sections is identical to that under cable + Japanese AT PSM.

$$Z' = Z'_A d_{X1} + \frac{1}{2}(d_1 - d_{X1})Z'_B + \frac{1}{4}k_1\frac{d_{X1}}{d_1}(Z'_E d_{X1} + Z'_F d_1) \quad (23)$$

Where  $Z'_A = \frac{1}{4}(Z_1 - 2Z_{31} + 2Z_3)$ ,  $Z'_B = \frac{1}{2}(Z_1 - Z_{32} + Z_{31} + 2Z_2 - 3Z_{12})$ ,  $Z'_E = Z_{13} + Z_{12} - Z_{23} - Z_{21}$ ,  $Z'_F = Z_{13} + Z_{23} - Z_{12} - Z_3$ .

When there are  $n$  trains in the line, the voltage drop  $\Delta U_k$  from TS exit to train  $k$  ( $k = 1, 2, \dots, n$ ) is obtained by using the superposition principle.

$$\Delta U_k = \Delta \varepsilon_k + \begin{cases} \sum_{m=1}^n Z_A d_{L_m} \mathbf{I}_m + Z_B \left(1 - \frac{d_{X_n}}{d_n}\right) d_{X_n} \mathbf{I}_n & k = n \\ \sum_{m=1}^k Z_A d_{L_m} \mathbf{I}_m + Z_B \left(1 - \frac{d_{X_k}}{d_k}\right) d_{X_k} \mathbf{I}_k + \sum_{m=k+1}^n Z_A d_{L_m} \mathbf{I}_m & k < n \end{cases} \quad (24)$$

$$\text{Where } \Delta \varepsilon_k = \begin{cases} \sum_{m=k-1}^{k-n_1} Z_B \left(1 - \frac{d_{X_m}}{d_k}\right) d_{X_m} I_m & k - n_1 \leq m \leq k - 1 \\ \sum_{m=k+1}^{k+n_2} Z_B \frac{d_{X_m}}{d_k} d_{X_k} I_m & k + 1 \leq m \leq k + n_2 \end{cases}$$

Where  $\Delta \varepsilon_k$  is the impact component of other trains in the same AT section of the short loop on the voltage drop of train  $k$ ,  $n_1$  and  $n_2$  are numbers of trains in front and at the rear of train  $k$  in the same AT section, respectively,  $I_m$ ,  $I_n$  and  $I_k$  are current phasors of train  $m$  ( $m = 1, 2, \dots, n$ ), train  $n$  and train  $k$ , respectively,  $d_k$  is the distance between two AT posts in the short loop where train  $k$  is located,  $d_{l_m}$  and  $d_{l_k}$  are distances from trains  $m$  and  $k$  to TS exit, respectively,  $d_{X_m}$  and  $d_{X_k}$  are distances from trains  $m$  and  $k$  to nearest AT post to TS.

The equivalent circuit model shown in Figure 4 is obtained in accordance with Equation (24). In the figure,  $T'$ ,  $R'$  and  $F'$  are simplified equivalent OCS, equivalent rail and equivalent negative feeder, respectively. For  $T'$  and  $R'$ , impedances per unit length are  $Z_A$  and  $Z_B$ , respectively. The equivalent negative feeder is deemed as an ideal conductor.

### 3.2 Chain circuit model

According to different power supply sections, continuous linear power flow calculation can be made by taking the feeding section, TS or entire line as a unit (He, Li, Liu, & Zhou, 2010; Wu, 2010; Zhang & Wu, 2018). The calculation is made as follows by taking the TS as a unit, with its chain circuit model shown in Figure 5. In the figure,  $\omega_1$  is the number of divided tangent planes of the TN;  $Z_\omega$  is the impedance matrix of series elements between tangent planes  $\omega$  ( $1 \leq \omega \leq \omega_1 - 1$ ) and  $\omega + 1$ ;  $Y_\omega$  is the admittance matrix of parallel elements at tangent plane  $\omega$ ;  $I_\omega$  is the injection current phasor at tangent plane  $\omega$ ; tangent planes  $\omega = \beta$  and  $\omega = \beta + 1$  are two equivalent port tangent planes of the traction transformer;  $Z_\beta$  is the impedance matrix of neutral section.

In Figure 5, the impedance and admittance matrixes per unit length of CTN are  $Z_L = \begin{pmatrix} Z_{\alpha_1} & 0 \\ 0 & Z_{\alpha_2} \end{pmatrix}$  and  $Y_L = \begin{pmatrix} Y_{\alpha_1} & 0 \\ 0 & Y_{\alpha_2} \end{pmatrix}$ , respectively, where  $\alpha_1$  and  $\alpha_2$  are wire numbers of TN and cable, respectively;  $Z_{\alpha_1}$  and  $Y_{\alpha_1}$  are impedance and admittance matrixes

Figure 4. Simplified equivalent circuit model

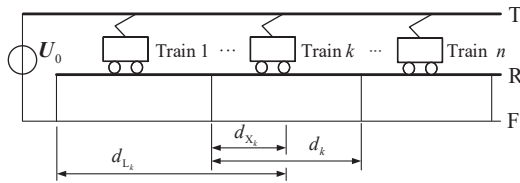
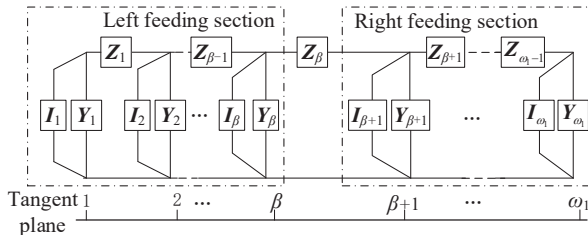

Figure 5. Chain circuit model



per unit length of TN, respectively;  $\mathbf{Z}_{\alpha_2}$  and  $\mathbf{Y}_{\alpha_2}$  are impedance and admittance matrixes per unit length of cable, respectively.  $\mathbf{Z}_L$  and  $\mathbf{Y}_L$  are block diagonal matrixes, respectively, and  $\mathbf{Z}_\omega$  and  $\mathbf{Y}_\omega$  obtained by using the matrix series algorithm to equalize the TN to  $\pi$ -shaped equivalent circuit are still block diagonal matrixes (Wu, 2010). Therefore, continuous linear power flow calculation can be made by applying direct inversion or taking block chasing method for solution (Wu, 2010).

#### 4. PSD of TN

The PSD of the TN, which directly affects the transport capacity of the line, is affected by system impedance, load magnitude and compensation mode. Whether the voltage of TN is qualified or not is related to the PSD of TN. The voltage drop equation  $\Delta \mathbf{U}'_1$  of  $n$  trains is obtained in accordance with (24) as follows:

$$\Delta \mathbf{U}'_1 = \mathbf{U}'_0 - \mathbf{U}'_1 = \mathbf{Z}'_1 \mathbf{I}'_1 \quad (25)$$

Where,

$$\begin{aligned} \mathbf{U}'_0 &= (\mathbf{U}_{01} \quad \mathbf{U}_{02} \quad \cdots \quad \mathbf{U}_{0k} \quad \cdots \quad \mathbf{U}_{0n})^T \\ \mathbf{U}'_1 &= (\mathbf{U}_1 \quad \mathbf{U}_2 \quad \cdots \quad \mathbf{U}_k \quad \cdots \quad \mathbf{U}_n)^T \\ \mathbf{I}'_1 &= (\mathbf{I}_1 \quad \mathbf{I}_2 \quad \cdots \quad \mathbf{I}_k \quad \cdots \quad \mathbf{I}_n)^T \\ \mathbf{Z}'_1 &= (\mathbf{Z}_{km})_{nm} \\ \mathbf{Z}_{km} &= \begin{cases} \mathbf{Z}_A d_{L_k} + \mathbf{Z}_B \left(1 - \frac{d_{X_k}}{d_k}\right) d_{X_k} & k = m \\ \mathbf{Z}_A d_{L_k} + \Delta \mathbf{Z}_{km} & k > m \\ \mathbf{Z}_A d_{L_m} + \Delta \mathbf{Z}_{km} & k < m \end{cases} \\ \Delta \mathbf{Z}_{km} &= \begin{cases} \mathbf{Z}_B \left(1 - \frac{d_{X_m}}{d_k}\right) d_{X_m} & k - n_1 \leq m \leq k - 1 \\ \mathbf{Z}_B \frac{d_{X_m}}{d_k} d_{X_k} & k + 1 \leq m \leq k + n_2 \end{cases} \end{aligned}$$

Where  $\mathbf{U}'_0$  and  $\mathbf{U}'_1$  are voltage matrixes at TS exit and train port, respectively,  $\mathbf{I}'_1$  is the train current matrix,  $\mathbf{U}_{0k} = \mathbf{U}_O$  is the voltage between  $T$  and  $R$  at TS exit,  $\mathbf{Z}'_1$  is the impedance matrix,  $\mathbf{Z}_{km}$  is the impedance of row  $k$  and column  $m$  in  $\mathbf{Z}'_1$ ,  $\Delta \mathbf{Z}_{km}$  is the impedance increment.

The following equation is obtained by obtaining  $\mathbf{Y}'_1 = (\mathbf{Z}'_1)^{-1}$ , inverse matrix of  $\mathbf{Z}'_1$ , and multiplying  $\mathbf{Y}'_1$  on both sides of (25).

$$\mathbf{I}'_1 = \mathbf{Y}'_1 \mathbf{U}'_0 - \mathbf{Y}'_1 \mathbf{U}'_1 \quad (26)$$

If the complex power of train  $k$  is  $P_k + jQ_k$ , the following power flow equation is obtained by taking it into (26).

$$P_k + jQ_k = \mathbf{U}_k \sum_{m=1}^n \mathbf{Y}_{km}^* \mathbf{U}_{0k}^* - \mathbf{U}_k \sum_{m=1}^n \mathbf{Y}_{km}^* \mathbf{U}_k^* \quad (27)$$

Where  $\mathbf{Y}_{km}$  is the admittance of row  $k$  and column  $m$  in  $\mathbf{Y}'_1$ .

By taking  $U_k = U_k \angle \delta_k$ ,  $U_m = U_m \angle \delta_m$ ,  $U_{0k} = U_{0k} \angle \delta_{0k}$ ,  $Y_{km} = G_{km} + jB_{km}$ ,  $\delta_{km} = \delta_k - \delta_m$ ,  $\lambda_k = \delta_k - \delta_{0k}$  into (27), the power flow equation under polar coordinates is obtained as follows:

$$\begin{cases} P_k = \sum_{m=1}^n U_k [U_{0k} (G_{km} \cos \lambda_k + B_{km} \sin \lambda_k) - U_m (G_{km} \cos \delta_{km} + B_{km} \sin \delta_{km})] \\ Q_k = \sum_{m=1}^n U_k [U_{0k} (G_{km} \sin \lambda_k - B_{km} \cos \lambda_k) - U_m (G_{km} \sin \delta_{km} - B_{km} \cos \delta_{km})] \end{cases} \quad (28)$$

Where  $U_k$ ,  $\delta_k$ ,  $U_m$  and  $\delta_m$  are voltage magnitudes and phase angles of trains  $k$  and  $m$ , respectively;  $U_{0k}$  and  $\delta_{0k}$  are port voltage magnitude and phase angle, respectively;  $G_{km}$  and  $B_{km}$  are electric conductance and susceptance in  $Y_{km}$ , respectively.

According to (28), the matrix form of correction equations of  $P_k$  and  $Q_k$  is obtained by using the Newton-Raphson method as follows:

$$\begin{pmatrix} \Delta P_n \\ \Delta Q_n \end{pmatrix} = \begin{pmatrix} H & N \\ J & L \end{pmatrix} \begin{pmatrix} \Delta \delta_n \\ \Delta U_n \end{pmatrix} \quad (29)$$

Where,

$$\begin{aligned} H &= (H_{km})_{nm} \\ N &= (N_{km})_{nm} \\ J &= (J_{km})_{nm} \\ L &= (L_{km})_{nm} \\ H_{km} &= \begin{cases} U_k U_m (G_{km} \sin \delta_{km} - B_{km} \cos \delta_{km}) & m \neq k \\ Q_k - U_k^2 B_{kk} & m = k \end{cases} \\ N_{km} &= \begin{cases} U_k U_m (G_{km} \cos \delta_{km} + B_{km} \sin \delta_{km}) & m \neq k \\ -P_k + U_k^2 G_{kk} & m = k \end{cases} \\ L_{km} &= \begin{cases} H_{km} & m \neq k \\ -Q_k - U_k^2 B_{kk} & m = k \end{cases} \\ J_{km} &= \begin{cases} -N_{km} & m \neq k \\ -P_k - U_k^2 G_{kk} & m = k \end{cases} \\ \Delta P_n &= (\Delta P_n \quad \Delta P_{n-1} \quad \cdots \quad \Delta P_2 \quad \Delta P_1)^T \\ \Delta Q_n &= (\Delta Q_n \quad \Delta Q_{n-1} \quad \cdots \quad \Delta Q_2 \quad \Delta Q_1)^T \\ \Delta \delta_n &= (\Delta \delta_n \quad \Delta \delta_{n-1} \quad \cdots \quad \Delta \delta_2 \quad \Delta \delta_1)^T \\ \Delta U_n &= \left( \frac{\Delta U_n}{U_n} \quad \frac{\Delta U_{n-1}}{U_{n-1}} \quad \cdots \quad \frac{\Delta U_2}{U_2} \quad \frac{\Delta U_1}{U_1} \right)^T \end{aligned}$$

Where  $\Delta P_k$ ,  $\Delta Q_k$ ,  $\Delta \delta_k$  and  $\Delta U_k$  are corrections of active power, reactive power, voltage phase angle and magnitude of train  $k$ , respectively;  $\Delta P_n$ ,  $\Delta Q_n$ ,  $\Delta \delta_n$  and  $\Delta U_n$  are correction matrixes

of active power, reactive power, voltage phase angle and magnitude at train  $k$ , respectively;  $H_{km}$ ,  $N_{km}$ ,  $J_{km}$  and  $L_{km}$  are elements of Jacobian matrix,  $\mathbf{H}$ ,  $\mathbf{N}$ ,  $\mathbf{J}$  and  $\mathbf{L}$  are matrix forms of elements of Jacobian matrix.

The voltage module value  $|\mathbf{U}_k|$  of high-speed trains meets  $|\mathbf{U}_k| \in [20, 29]$  kV (National Technical Committee on Electric Equipment and Systems for Railways of Standardization Administration of China, 2011). The longest PSD of CTN can be obtained by acquiring the train load process, updating the train position in the line at certain departure interval or departure distance and obtaining the voltage at train port in accordance with (29) where the voltage shall not be lower than the minimum voltage required. From the perspective of the train operation diagram, the calculation process of determining the PSD of CTN is obtained by taking departure interval  $T$  as an example.

- (1) The load process data of the train is obtained by determining departure interval  $T$ , setting the initial value of Time  $t$  as 0 and taking the port of feeding section as the starting point (namely, the data refer to train position  $l(t)$  at time  $T$  and complex power  $P(t) + jQ(t)$ ).
- (2) The number of trains in the line is determined as  $n = \text{floor}(\frac{t-1}{T}) + 1$ , where floor is a rounding function. Trains are numbered from TS exit, recorded as trains 1, 2,  $\dots$ ,  $n$ . The position and power data of numbered trains are to be obtained.
- (3) Equivalent impedances ZA and ZB are evaluated in accordance with Equation (22) by determining the PSM and calculating the impedance data of the TN. The impedance matrix  $Z'_1$  is evaluated in accordance with (25).
- (4) The power flow calculation is made in accordance with (29) to evaluate the train port voltage. Specific steps are as follows:
  - Set the initial magnitude  $U_k^0$  and phase angle  $\delta_k^0$  of the voltage at TS exit and both ends of train  $k$ .
  - By setting the iterations as  $p$ , voltage magnitude and phase angle at both ends of the train is  $U_k^p$  and  $\delta_k^p$ , respectively in the  $p$ th iteration, and  $U_k^0$  and  $\delta_k^0$ , respectively, in the  $p = 1$  iteration.
  - $\Delta P_k$  and  $\Delta Q_k$  in the  $p$ th iteration are evaluated in accordance with (28), and the Jacobian matrix is determined in accordance with (29) to evaluate  $\Delta \delta_n$  and  $\Delta U_n$ .
  - Update new values of voltage magnitude and phase angle of the train port.
  - Set convergence precisions of voltage magnitude and phase angle as  $\varepsilon_U$  and  $\varepsilon_\delta$ , respectively, judge whether calculation results converge and turn to Step (5) if  $|\Delta U_k| < \varepsilon_U$  and  $|\Delta \delta_k| < \varepsilon_\delta$ ; but if not, perform the  $p + 1$ th iteration and turn to Step (3).
- (5) Judge whether train voltage meets the requirements, namely,  $|\mathbf{U}_k| \in [20, 29]$  kV, and check the power supply capacity of the system (for the moment, the minimum voltage of the train can be considered as over 20 kV or 22.5 kV). If train voltage meets the requirements, make calculations in the next 1s or turn to Step (2); if not, turn to Step (6).
- (6) End. The longest PSD of single feeding section of the CTN is determined.

## 5. Simulation analysis

### 5.1 Impedance module value of CTN

Two-core cables are added on the basis of the TN line under AT PSM to simulate the scheme of long distance power supply under cable + AT PSM. By taking the two-core cable

with 300 m<sup>2</sup> cross-sectional area as an example, the schemes under three cable + AT PSMs can be formed in accordance with different AT PSMs. By taking a single track as an example despite the impact of the protective wire and adopting 220 kV external power supply, JTMH-120 messenger wire, CTMH-150 contact wire, P60 rail and LGJ-185 negative feeder, the equivalent impedance of the TN in the up direction traffic is analyzed, and equivalent impedance module value of the TN/km from TS exit under three cable + AT PSMs and three AT PSMs is calculated as shown in Figure 6.

It can be seen from Figure 6 that from the second AT section, the equivalent impedance module value of the TN under three cable + AT PSMs varies in saddle shape the same as that under AT PSMs, but is smaller than that under AT PSMs; the equivalent impedance module value of the TN under cable + Japanese AT PSM is identical to that under cable + French AT PSM, except that in the first AT power supply section, the curve of equivalent impedance module value of the TN under cable + new AT PSM in other AT sections is identical to that under cable + Japanese (French) AT PSM.

The influence of the distance between adjacent AT posts on the equivalent impedance module value of the TN is analyzed by taking Japanese AT PSM and cable + Japanese AT PSM as examples. By setting 10 km distance between adjacent AT posts under Japanese AT PSM and 10, 11, 12 and 13 km distances between adjacent AT posts under cable + Japanese AT PSM, equivalent impedance module values of the TN under different PSMs are calculated with the calculating results shown in Figure 7. It can be seen from Figure 7 that within a certain range, longer distance between adjacent AT posts under cable + AT PSM causes larger maximum value of equivalent impedance module value of the TN of the short loop; compared with Japanese AT PSM, the equivalent impedance module value of the TN under cable + AT PSM is smaller, so longer distance can be set between adjacent AT posts.

5.2 PSD of CTN

The PSD of CTN is analyzed by setting 250 km · h<sup>-1</sup> train speed, 9.6 and 19.6 MW train power, 0.98 train power factor and 12 km distance between AT posts and taking Japanese AT PSM and cable + Japanese AT PSM as examples. Under the situation of 27.5 and 25.0 kV voltage at TS exit and 6, 7 and 8 min intervals of train departure, PSDs of the TN under Japanese AT

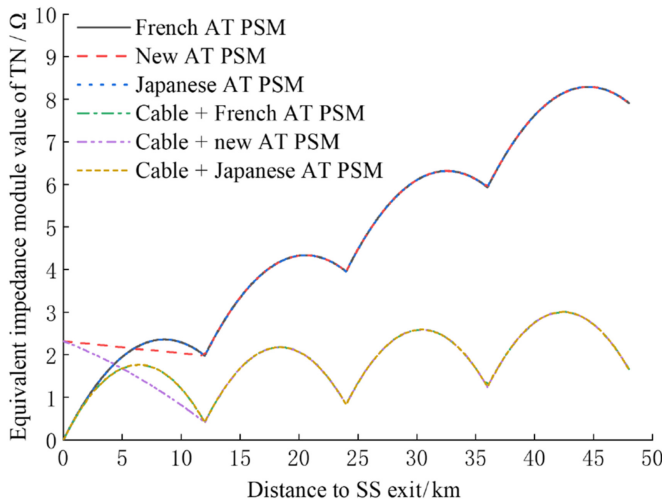
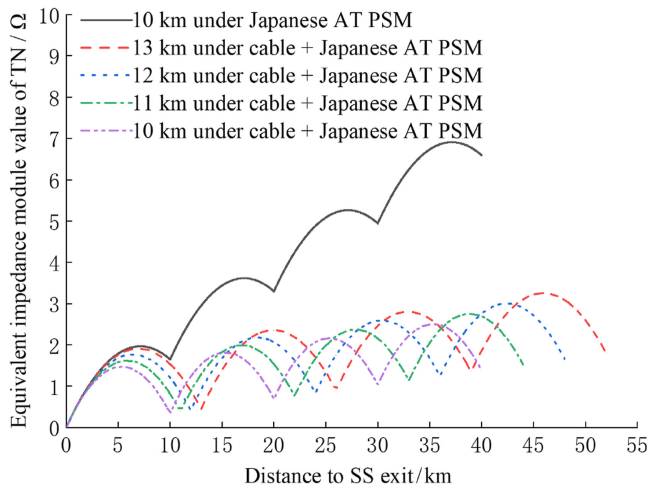

Figure 6. Equivalent impedance module value of TN under different PSMs



**Figure 7.**  
Equivalent impedance  
module values of TN at  
different distances  
between adjacent  
AT posts

PSM and cable + Japanese AT PSM are calculated in accordance with the contents of Subsection 3.

By taking 6 min departure interval as an example, calculating results of PSDs of CTN is shown in Figure 8, where limit 1 is 22.5 kV, the lowest normal working voltage of the train, and limit 2 is 20.0 kV, the lowest working voltage of the train. Statistical results of the longest PSD of CTN are shown in Table 1. It can be seen from Table 1 that under the same traction load, the PSD of CTN under cable + AT PSM is about 2.5 times of that under AT PSM.

The longest PSDs of TN at 12, 13, 14, 15 and 16 km distances between adjacent AT posts under Japanese AT PSM and under cable + Japanese AT PSM are analyzed by setting 9.6 MW train power, 22.5 kV lowest normal working voltage of the train, 6 min departure interval and keeping other parameters unchanged, with calculating results shown in Table 2.

It can be seen from Table 2 that the longest PSD of the TN at different distances between adjacent AT posts under cable + AT PSM is about 2.5 times of that under Japanese AT PSM. Therefore, the distance between adjacent AT posts can be increased by adopting cable + AT PSM.

### 5.3 Practical calculation

By taking fully parallel AT power supply line of a double track as an example, where set parameters of the external power supply and TN are the same as those in Section 5.1, the train model is CRH380A, the power factor is 0.98 and the line is 145.15 km, the existing power supply scheme refers to the scheme of three TSs under AT PSM, as shown in Figure 9a, where A3, A7 and A11 are TSs; A1, A5, A9 and A13 are section posts and others are AT posts. According to the method described in Section 3, three schemes under cable + AT PSM can be obtained by determining the PSD of a single feeding section. These schemes can be of co-phase/out-of-phase power supply and divided into the scheme of three TSs under cable + AT PSM, scheme of two TSs under cable + AT PSM (as shown in Figure 9b) and scheme of a TS under cable + AT PSM (as shown in Figure 9c). The distribution of TSs is the same for the scheme of three TSs under cable + AT PSM and the scheme of three TSs under AT PSM. In Figure 9b, B2 is the section post, B1 and B3 are AT posts and other settings remain unchanged; in Figure 9c, C2 and C4 are mutually standby TSs, C1, C3 and C5 are AT posts and other settings remain unchanged.

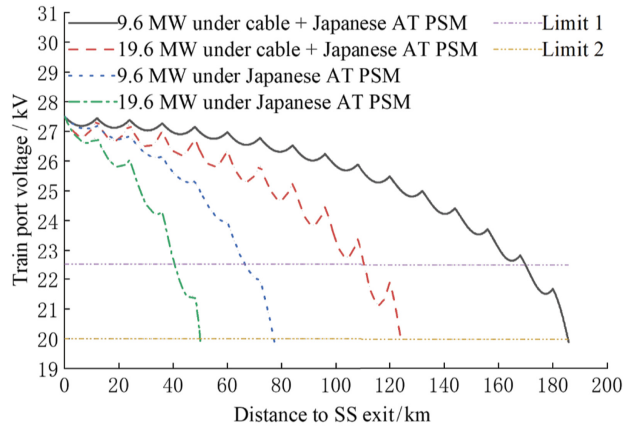

(a)

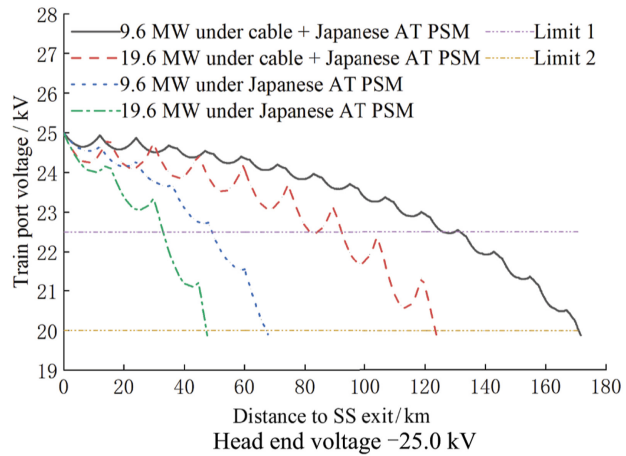

(b)

**Figure 8.**  
PSD of CTN at 6 min  
departure interval  
under different PSMs

Train power/MW	Port voltage/kV	Longest PSD of CTN/km					
		At different departure intervals under Japanese AT PSM			At different departure intervals under cable + Japanese AT PSM		
		6 min	7 min	8 min	6 min	7 min	8 min
9.6	27.5	60	72	72	168	180	180
	25.0	48	48	48	120	132	144
19.6	27.5	36	36	48	108	108	120
	25.0	24	24	24	60	60	60

The minimum departure intervals in the long term and short term are 4 min and 5 min, respectively, to ensure the margin of line operation. The minimum voltages of the TN at different positions and two departure intervals in four schemes are shown in Figures 10 and 11, respectively.

Statistics are made on the minimum voltages of the TN along the entire line in four power supply schemes shown in Figures 10 and 11, with statistical results shown in Table 3. It can be seen from Table 3 that the minimum voltage of the TN in the scheme of a TS under

Distance between adjacent AT posts	km	
	Japanese AT PSM	Cable + Japanese AT PSM
12	60	168
13	65	169
14	56	168
15	60	165
16	64	160

**Table 2.** Longest PSDs of TN at different distances between adjacent AT posts

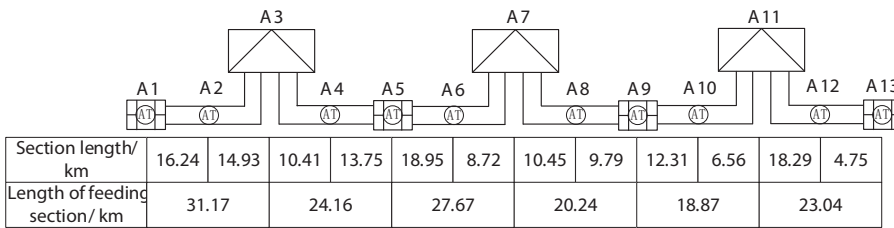

Schemes of three TSs under AT PSM

(a)

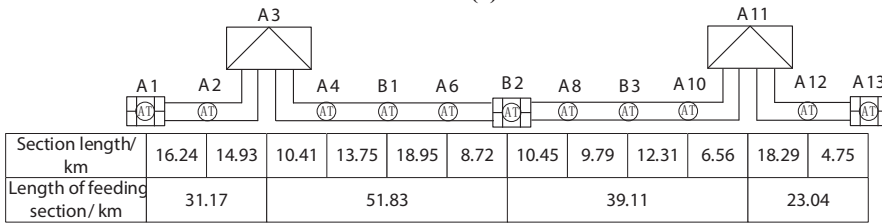

Scheme of two TSs under cable + AT PSM

(b)

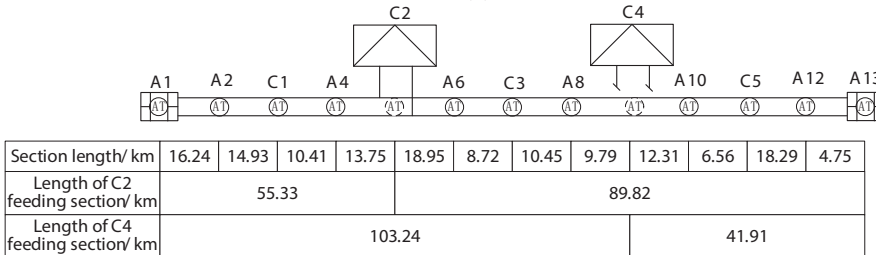

Scheme of a TS under cable + AT PSM

(c)

**Figure 9.** Distribution of power supply section in different power supply schemes

cable + AT PSM is lowest, but higher than 22.5 kV, in which the train can still be under normal operation; the minimum voltage of the TN in schemes of two and three TSs under cable + AT PSM is larger than that in the scheme of a TS under AT power supply, meeting the requirement of normal working voltage of the train; considering the decrease in numbers of neutral sections and external power supplies, the co-phase power supply scheme of a TS/two TSs under cable + AT PSM can be considered, though four power supply schemes are all feasible.

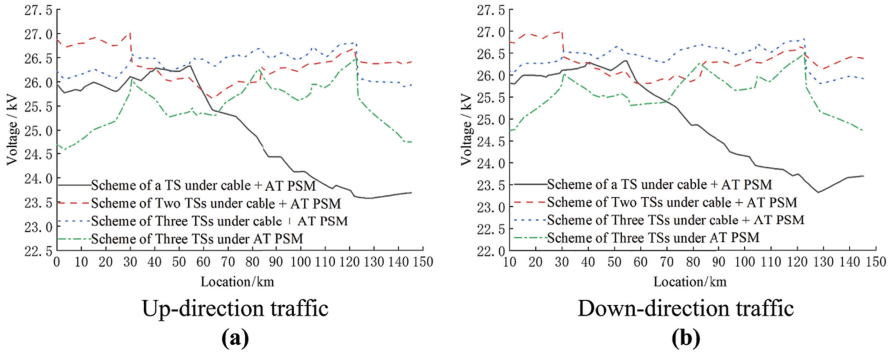

**Figure 10.** Distribution of minimum voltage of TN at 4 min departure interval in long term

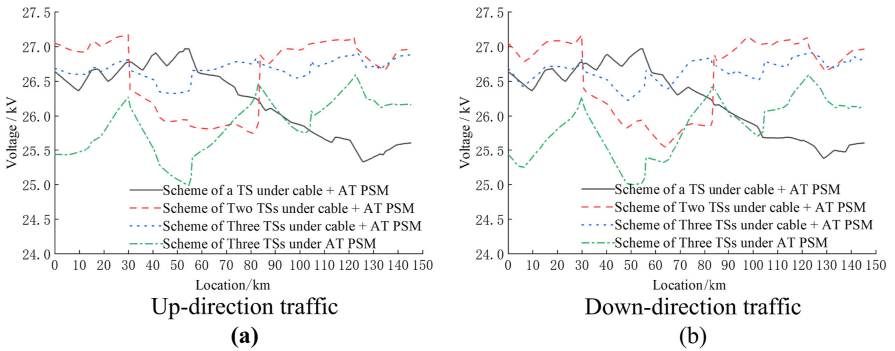

**Figure 11.** Distribution of minimum voltage of TN at 5 min departure interval in recent term

Power supply scheme	kV			
	4 min departure interval Up-direction traffic	4 min departure interval Down-direction traffic	5 min departure interval Up-direction traffic	5 min departure interval Down-direction traffic
Scheme of three TSs under AT PSM	24.57	24.70	24.99	24.99
Cable + AT PSM	25.90	25.81	26.33	26.22
Scheme of three TSs	25.66	25.79	25.75	25.55
Scheme of two TSs	25.66	25.79	25.75	25.55
Scheme of a TS	23.59	23.33	25.33	25.38

**Table 3.** Minimum voltage of CTN along entire line

## 6. Conclusion

The PSMs of long-distance power supply scheme of CTN include cable + direct supply mode and cable + AT PSM. The main example is the cable + AT PSM, which was studied from different points of view. The method of determining the PSD of CTN was proposed by taking the working voltage of the train as the constraint condition and on the basis of the power flow calculation model of train load. Simulated analysis was made for the impedance and PSD of CTN, respectively, and scheme design and comparison were made by taking a line as an example, which indicates that the equivalent impedance of traction network is smaller by taking the scheme under cable + AT PSM; the PSD under cable + AT PSM is about 2.5 times of that under AT PSM, so cable + AT PSM can effectively lengthen the PSD and achieve more flexible location selection for external power supplies.

Models described in this paper are still applicable to cable + direct supply mode, and the scheme is also applicable to new lines and existing lines of urban railways, heavy haul railways and lines with long steep grades; the scheme, if further combined with new PSMs and new technologies, can further help improve the PSD of TPSS.

## References

- Chen, M., Zhou, Y., Han, X., Yang, H., Zhou, Z., & Sun, L. (2019). Scheme optimization for co-phase continuous traction power supply based on LCC in area with weak external power source. *China Railway Science*, 40, 103–111.
- Hartmut, B., Erich, B., Gerhard, G., Karl-Heinz, G., Gerhard, H., Ralf, K., . . . , & Arnd, S. (2019). *Traction Power Supply System of Electrified Railway*. Translated by Qi, G. Beijing: China Railway Publishing House.
- He, J., Li, Q., Liu, W., & Zhou, X. (2010). General mathematical model for simulation of AC traction power supply system and its application. *Power System Technology*, 34, 25–29.
- Li, Q. (2010). On some technical key problems in the development of traction power supply system for high-speed railway in china. *Journal of the China Railway Society*, 32, 119–124.
- Li, Q. (2014). On new generation traction power supply system and its key technologies for electrification railway. *Journal of Southwest Jiaotong University*, 49, 559–568.
- Li, Q. (2015). Industrial frequency single-phase AC traction power supply system and its key technologies for urban rail transit. *Journal of Southwest Jiaotong University*, 50, 199–207.
- Li, Q., & He, J. (2012). *Analysis of Traction Power Supply System* (3rd ed.). Chengdu: Southwest Jiaotong University Press.
- Liu, W., Liu, X., Wang, H., Wang, C., & Li, Q. (2019). Power supply scheme of traction power supply system for city railway based on SVG. *China Railway Science*, 40, 129–136.
- National Technical Committee on Electric Equipment and Systems for Railways of Standardization Administration of China (2011). *GB/T 1402—2010 voltage of traction power supply system of rail transit*. Beijing: China Standard Press.
- Wang, H. (2017). *Research on Long Distance Power Supply Technical Scheme for the Electrified Railway*. Chengdu: Southwest Jiaotong University.
- Wang, H., Li, Q., Li, J., Xie, S., & Huang, W. (2020a). Comprehensive compensation schemes of co-phase power supply of electrified railway based on YNd transformer and static var generator. *Transactions of China Electrotechnical Society*, 35, 3739–3749.
- Wang, H., Li, Q., Xie, S., & Zhang, Y. (2020b). Comprehensive compensation scheme of co-phase power supply for electrified railway with Dd transformer and static var generator. *China Railway Science*, 41, 116–126.
- Wu, F. (2016). Key techniques of traction power supply system in heavy-haul railway. *Railway Construction Technology*, 1, 64–67.

- Wu, M. (2010). Uniform chain circuit model for traction networks of electric railways. *Proceedings of the CSEE*, 30, 52–58.
- Zhang, J., & Wu, M. (2018). Power flow algorithm for electric railway traction network based on multiple load port thévenin equivalence. *Transactions of China Electrotechnical Society*, 33, 2479–2485.
- Zhou, Z. (2020). Co-phase connected power supply scheme of heavy haul railway based on tree bilateral power supply. *Journal of Railway Science and Engineering*, 17, 722–731.

**Corresponding author**

Hui Wang can be contacted at: [wanghuiswjt@163.com](mailto:wanghuiswjt@163.com)