

Estimation and prediction of plastic waste annual input into the sea from China

BAI Mengyu¹, ZHU Lixin¹, AN Lihui², PENG Guyu¹, LI Daoji^{1*}

¹ State Key Laboratory of Estuarine and Coastal Research, East China Normal University, Shanghai 200062, China

² State Environmental Protection Key Laboratory of Estuarine and Coastal Research, Chinese Research Academy of Environmental Sciences, Beijing 100012, China

Received 23 August 2018; accepted 12 October 2018

© Chinese Society for Oceanography and Springer-Verlag GmbH Germany, part of Springer Nature 2018

Abstract

Marine plastic debris has been a pervasive issue since the last century, and research on its sources and fates plays a vital role in the establishment of mitigation measures. However, data on the quantity of plastic waste that enters the sea on a certain timescale remain largely unavailable in China. Here, we established a model using material flow analysis method based on life cycle assessment to follow plastic product from primary plastic to plastic waste with statistical data and monitoring data from accurate sources. This model can be used to estimate and forecast the annual input of plastic waste into the sea from China until 2020. In 2011, 0.547 3–0.751 5 million tons of plastic waste entered the seas in China, with a growth rate of 4.55% per year until 2017. And the amount will decrease to 0.257 1 to 0.353 1 million tons in 2020 under the influence of governmental management. The amount of plastic waste discharged from coastal areas calculated in this study was much larger than that from river, thus it is suggested to strengthen the governance and control of plastic waste in coastal fishery activities in China in order to reduce the amount of marine plastic waste input.

Key words: plastic waste, prediction, China, marine, material flow analysis

Citation: Bai Mengyu, Zhu Lixin, An Lihui, Peng Guyu, Li Daoji. 2018. Estimation and prediction of plastic waste annual input into the sea from China. *Acta Oceanologica Sinica*, 37(11): 26–39, doi: 10.1007/s13131-018-1279-0

1 Introduction

After the first piece of plastic debris was discovered in the sea in the early 1970s (Carpenter and Smith, 1972; Fowler, 1987; Colton et al., 1974), plastic has been pervasive in all habitat types worldwide due to its durability, low density and universal use (Derraik, 2002). Plastic debris has appeared in gulfs (Hinojosa and Thiel, 2009), bays (Ryan, 2013), and lakes (Free et al., 2014), on the shores of the remotest islands (Barnes, 2005; Morishige et al., 2007), in polar waters (Barnes et al., 2010; Bergmann and Klages, 2012), and in high concentrations in the Great Pacific Garbage Patch (Lebreton et al., 2018). Marine plastic debris and microplastics may affect the survival of marine organisms. They may threaten the health of marine organisms by causing entanglement (Derraik, 2002; Gregory, 2009), destroying habitats (Donohue et al., 2001; Barnes, 2002), and choking and starving wildlife (Wright et al., 2013) etc. The United Nations Environment Assembly (UNEA) classified marine plastic debris and microplastics as one of several environmental issues of particular concern in 2016.

Plastic debris can enter the sea by three ways: direct littering to rivers, beaches and the seas (Lebreton et al., 2017); dispersal by water and wind (Kershaw and Rochman, 2015); and losses during transport or by accident (Barnes et al., 2009). Quantitative research on the sources and fates of marine plastic debris plays a very important guiding role in mitigating and minimizing the effects of marine plastic debris on the environment. Eriksen et al. (2014) calculated the quantity of macroplastics and micro-

plastics using a modeling approach and concluded that the amount of plastic debris in the North Pacific is 0.096 4 million tons (Mt), while the amount in the South Pacific is 0.021 0 Mt. Jambeck et al. (2015) estimated that in 2010, 1.32–3.53 Mt of mismanaged plastic waste was input from land into the sea in China. Meanwhile, rivers are a major transport pathway for plastic waste from land to sea. After summing the inputs from the 5 rivers in China, Schmidt et al. (2017) concluded that the annual load of macroplastic input from China into the sea was 0.094 5 Mt. Lebreton et al. (2017) estimated the aggregate annual macro- and microplastic input from the Xijiang and Dongjiang Rivers, which flow into the Zhujiang River Delta and Changjiang River, to be 0.436 Mt.

To investigate the temporal trends of plastic garbage entering the sea in China over a ten-year time period, in this study, a model was first established based on the material flow analysis method. Material flow analysis (MFA) is a systematic assessment tool used to determine the flows and stocks of materials within a system defined in space and time (Van Eygen et al., 2017). The main components of an MFA model include the sources, pathways, intermediates and final sinks of a material. All inputs, stocks, and outputs of a material within the model are balanced according to the law of conservation of mass (Brunner and Rechberger, 2004). This study connected processes ranging from the production of primary plastic to the discharge of plastic waste into sea in China using the flows of plastics, evaluated material inputs throughout the lifecycles of plastic products, and finally, estimated and pre-

Foundation item: The National Key Research and Development Program of China under contract No. 2016YFC1402200; the National Natural Science Foundation of China under contract No. 41676190.

*Corresponding author, E-mail: daoji@sklec.ecnu.edu.cn

dicted the amount of plastic waste entering the sea from China from 2011 to 2020.

2 Materials and methods

2.1 Material flow analysis model

The MFA model combined the available datasets on primary plastic, plastic products, plastic waste and plastic garbage in China from 2011 to 2017. And it also incorporated opinions from industry professionals and actual data to improve the accuracy of the datasets and the consistency of plastic product classification. Plastic garbage not subjected to harmless treatment which include directly discarded mass was defined as mismanaged plastic waste. By combining the rates of plastic waste input into the sea, the total amount of plastic waste entering the sea in China could be determined. Lastly, this model predicted the amount of plastic waste that will be discharged into the sea from 2018 to 2020 affected by government laws and regulations. The predicted amount of plastic waste that will enter the sea from China from

2018 to 2020 can serve as a reference for the government and inhabitants to provide a better understanding of and means to control plastic waste.

Figure 1 is a simplified schematic of the MFA model adopted in this study. The “input” in the MFA model has five components: (1) import of primary plastic, (2) primary plastic production, (3) import of plastic products, (4) export of plastic products, and (5) import of plastic waste. The MFA model is divided into Fractions A and B, which are both complete MFA models. In Fraction A, the inputs pass through a simple expression of the processes named “produce and scrap”; thus, the amount of “plastic garbage”, which is the annual amount of plastic garbage generated in China, can be estimated. The amount of “plastic garbage” is the output of Fraction A and serves as the input to Fraction B, while the “Output” of Fraction B and the overall MFA model is the amount of plastic waste entering the sea. Detailed information about the flows and coefficients in Fractions A and B of the MFA model is presented in Sections 3.1 and 3.2.

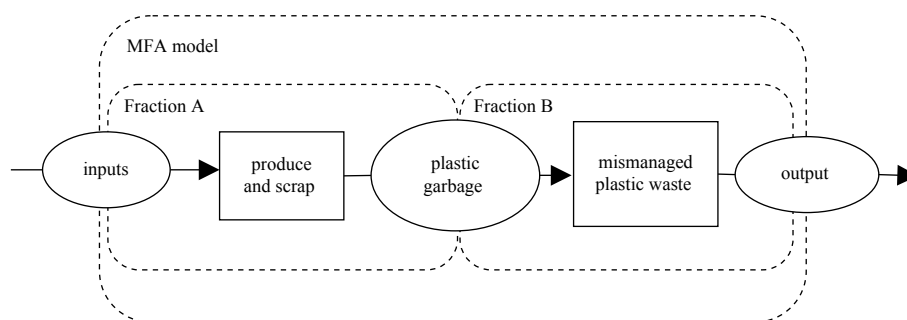

Fig. 1. A simplified schematic model of plastic waste entering the sea in China. Fractions A and B are both complete MFA models. Fraction A is used to estimate the amount of plastic garbage generated in China, and Fraction B is used to estimate the amount of plastic waste entering the sea from China. The “inputs” have five components: import of primary plastic, primary plastic production, import of plastic products, export of plastic products and import of plastic waste. The “output” is the amount of plastic waste entering the sea from China. “produce and scrap” and “mismanaged plastic waste” are simple expressions of the corresponding processes.

2.2 Dataset for the model

Before 2011, the official statistical data originated from industrial enterprises with annual revenues of more than 5 million yuan from their main business operations according to the National Bureau of Statistics of the People’s Republic of China (PRC) and the General Administration of Customs of the PRC. Since 2011, data have been collected from enterprises with annual revenues of more than 20 million yuan. For data consistency, the official data from 2011 to 2017 were selected for this study.

Three types of data sources were used in this study: data from official national statistics, data from relevant reports and publications and data from field surveys. The official national statistics include data from the National Bureau of Statistics of the PRC, the General Administration of Customs of the PRC, the Ministry of Commerce of the PRC, the National Development and Reform Commission and other governmental agencies. The referenced reports and publications were mainly compiled by the China Plastic Processing Industry Association (CPPIA), the China Scrap Plastics Association (CSPA) and market research firms. Field surveys referred to sampling and investigation conducted in a typical coastal city (Wenzhou, Zhejiang province) in China to obtain the amount of plastic waste entering sea from coastal areas. Section 2.4, Tables 1 and 2 show the data sources and methods used to calculate the coefficients.

2.3 Prediction

To predict the amount of plastic waste discharged into the sea, two conditions were established in this study: Condition 1 is prediction using only the MFA model, and Condition 2 is prediction based on the MFA model while considering impacts from reducing actions of plastic waste production and import.

In Condition 1, the model inputs were predicted by using the available data to build trend lines over the years (Fig. 2), and strong relationships were found ($R^2 > 0.88$). The production, import and export of primary plastic will all increase after 2017, while the import of plastic products and production of plastic products will decrease after 2017. All inputs except for the import of plastic waste originate from data from official sources from 2011 to 2017, as shown in Table 1.

The import of plastic waste exhibits a linear decrease beginning in 2018 because of China’s ban on importing plastic waste; therefore, we utilized the data predicted by the CSPA (Fan, 2018) in 2018 and considered the amount of imported plastic waste to be zero after 2019. By predicting the model inputs from 2018 to 2020 and assuming that the coefficients will not change over time, the model output, which is the annual amount of plastic waste entering the sea in China, can be determined accordingly.

In Condition 2, the influences of reducing actions were combined with the results of Condition 1 to forecast the amount of plastic waste entering the sea in China in response to powerful

Table 1. Coefficients in Fraction A of the MFA model

	Description	Calculation method	Mean/%	Std/%	Sources
W_{PL}	ratio of primary plastics made into plastic products	plastic product production/primary plastic production	73.51	2.48	CPPIA (2012, 2013, 2014, 2015, 2016, 2017); National Bureau of Statistics of the PRC (2018)
W_{I1}	import ratio of plastic film	amount of plastic film imports/amount of all plastic product imports	48.01	5.29	CPPIA (2012, 2013, 2014, 2015, 2016, 2017); General Administration of Customs of the PRC (2018); Zhong Jin Qi Xin Beijing International Information Consultation Co. (2018)
W_{I2}	import ratio of plastic foam	amount of plastic foam imports/amount of all plastic product imports	4.58	0.42	CPPIA (2012, 2013, 2014, 2015, 2016, 2017); General Administration of Customs of the PRC, (2018); Zhong Jin Qi Xin Beijing International Information Consultation Co. (2018)
W_{I3}	import ratio of synthetic leather	amount of synthetic leather imports/amount of all plastic product imports	2.90	0.35	CPPIA (2012, 2013, 2014, 2015, 2016, 2017); General Administration of Customs of the PRC, (2018); Zhong Jin Qi Xin Beijing International Information Consultation Co. (2018)
W_{I4}	import ratio of plastic commodities	amount of plastic commodity imports/amount of all plastic product imports	2.63	0.59	CPPIA (2012, 2013, 2014, 2015, 2016, 2017); General Administration of Customs of the PRC (2018); Zhong Jin Qi Xin Beijing International Information Consultation Co. (2018)
W_{I5}	import ratio of other types	amount of other import types/amount of all plastic product imports	41.10	15.19	CPPIA (2012, 2013, 2014, 2015, 2016, 2017); General Administration of Customs of the PRC (2018); Zhong Jin Qi Xin Beijing International Information Consultation Co. (2018)
W_{P1}	processing ratio of plastic film	plastic film production/all plastic product production	17.45	0.61	CPPIA (2012, 2013, 2014, 2015, 2016, 2017); General Administration of Customs of the PRC (2018); Zhong Jin Qi Xin Beijing International Information Consultation Co. (2018)
W_{P2}	processing ratio of plastic foam	plastic foam production/all plastic product production	2.86	0.36	CPPIA (2012, 2013, 2014, 2015, 2016, 2017); General Administration of Customs of the PRC (2018); Zhong Jin Qi Xin Beijing International Information Consultation Co. (2018)
W_{P3}	processing ratio of synthetic leather	synthetic leather production/all plastic product production	4.89	0.56	CPPIA (2012, 2013, 2014, 2015, 2016, 2017); General Administration of Customs of the PRC (2018); Zhong Jin Qi Xin Beijing International Information Consultation Co. (2018)
W_{P4}	processing ratio of plastic commodities	plastic commodity production/all plastic product production	7.98	0.28	CPPIA (2012, 2013, 2014, 2015, 2016, 2017); General Administration of Customs of the PRC (2018); Zhong Jin Qi Xin Beijing International Information Consultation Co. (2018)
W_{P5}	processing ratio of other types	other types production/all plastic product production	66.97	0.21	CPPIA (2012, 2013, 2014, 2015, 2016, 2017); General Administration of Customs of the PRC (2018); Zhong Jin Qi Xin Beijing International Information Consultation Co. (2018)
W_{E1}	export ratio of plastic film	amount of plastic film exports/amount of all plastic product exports	15.19	0.95	CPPIA (2012, 2013, 2014, 2015, 2016, 2017); General Administration of Customs of the PRC (2018); Zhong Jin Qi Xin Beijing International Information Consultation Co. (2018)
W_{E2}	export ratio of plastic foam	amount of plastic foam exports/amount of all plastic product exports	1.88	0.08	CPPIA (2012, 2013, 2014, 2015, 2016, 2017); General Administration of Customs of the PRC (2018); Zhong Jin Qi Xin Beijing International Information Consultation Co. (2018)
W_{E3}	export ratio of synthetic leather	amount of synthetic leather exports/amount of all plastic product exports	3.84	0.30	CPPIA (2012, 2013, 2014, 2015, 2016, 2017); General Administration of Customs of the PRC (2018); Zhong Jin Qi Xin Beijing International Information Consultation Co. (2018)
W_{E4}	export ratio of plastic commodities	amount of plastic commodity exports/amount of all plastic product exports	19.12	4.43	CPPIA (2012, 2013, 2014, 2015, 2016, 2017); General Administration of Customs of the PRC (2018); Zhong Jin Qi Xin Beijing International Information Consultation Co. (2018)
W_{E5}	export ratio of other types	amount of other types of plastic exports/amount of all plastic product export	57.58	0.73	CPPIA (2012, 2013, 2014, 2015, 2016, 2017); General Administration of Customs of the PRC (2018); Zhong Jin Qi Xin Beijing International Information Consultation Co. (2018)
W_{W1}	scrap ratio of plastic film	amount of plastic film scraps/amount of all plastic product scraps	68.39	0.00	National Bureau of Statistics of the PRC (2018); Zhiyan Consulting Group (2015)
W_{W2}	scrap ratio of plastic foam	amount of plastic foam scraps/amount of all plastic product scraps	98.11	0.00	National Bureau of Statistics of the PRC (2018); Zhiyan Consulting Group (2015)
W_{W3}	scrap ratio of synthetic leather	amount of synthetic leather scraps/amount of all plastic product scraps	9.81	0.00	National Bureau of Statistics of the PRC (2018); Zhiyan Consulting Group (2015)

to be continued

Continued from Table 1

	Description	Calculation method	Mean/%	Std/%	Sources
W_{W4}	scrap ratio of plastic commodities	amount of plastic commodity scraps/amount of all plastic product scraps	69.16	0.00	National Bureau of Statistics of the PRC (2018); Zhiyan Consulting Group (2015)
W_{W5}	scrap ratio of plastic scraps	amount of other types of plastic scraps/amount of all plastic product scraps	36.04	0.00	National Bureau of Statistics of the PRC (2018); Zhiyan Consulting Group (2015)
W_R	recycling ratio of plastic waste	amount of recycled plastic waste/amount of all plastic waste	47.21	2.29	Ministry of Commerce of the PRC (2014, 2016, 2017); National Development and Reform Commission of the PRC (2013)
W_{UR}	unrecycled ratio of plastic waste	amount of plastic garbage/amount of all plastic waste	52.79	2.29	Ministry of Commerce of the PRC (2014, 2016, 2017); National Development and Reform Commission of the PRC (2013)
Q_{PD}	plastic product production	$Q_{PD} = (Q_{PP} + I_{PP}) \times W_{PD}$			CPPIA (2012, 2013, 2014, 2015, 2016, 2017)
Q_{Pi}	production of each category of plastic products	$Q_{Pi} = I_P W_L + Q_{PD} W_{Pi} - E_P W_{Ei}$			CPPIA (2012, 2013, 2014, 2015, 2016, 2017); Ma (2018)
Q_W	waste plastic production	$Q_W = \sum_i^N Q_{Pi} W_{Wi} \quad i = 1 - 5,$ $N=5$			National Bureau of Statistics of the PRC (2018)
Q_R	recycled amount of plastic waste	$Q_R = (Q_W + I_W) \times W_R$			Ministry of Commerce of the PRC (2014, 2016, 2017)
Q_{UR}	amount of plastic garbage	$Q_{UR} = (Q_W + I_W) \times W_{UR}$			Ministry of Commerce of the PRC (2014, 2016, 2017)

Table 2. Characteristic comparison of ten rivers into the sea in China

River	River length/km	Runoff*/10 ⁹ m ³	Basin area*/10 ⁴ km ²	Basin population/10 ⁴ person
Huangpu River	113	10.00	2.40	4 001.00
Liaohe River	1 345	2.50	12.64	3 473.09
Haihe River	1 090	3.03	8.40	15 150.00
Qiantang River	588	27.64	2.44	1 607.00
Ouhe River	384	20.27	1.81	469.00
Huaihe River	1 000	28.09	13.16	16 043.00
Zhujiang River	2 320	349.30	41.52	12 558.00
Changjiang River	6 397	1 045.00	170.54	40 000.00
Huanghe River	5 464	16.50	68.22	11 368.23
Minhe River	562	100.60	5.85	1 180.00

Note: * The Ministry of Water Resources of the PRC (2017).

reducing actions. Reducing actions will cut down the amounts of mismanaged plastic waste and imported plastic waste, ultimately reducing the input of plastic waste into the sea. Due to the powerful governmental control of mismanaged domestic garbage in terms of improving the ratios of rural and urban domestic waste that undergo harmless treatment (Ministry of Commerce of the People’s Republic of China and MOHURD, 2015; Ministry of Commerce of the PRC and Ministry of Ecology and Environment of the PRC, 2016; Shanghai Administration Department of Afforestation and City Appearance, 2018), along with classifying and recycling rural and urban domestic garbage and agricultural film (Ministry of Agriculture of the PRC, 2017) and other actions and regulations from 2018, we used a range of decrease rates for mismanaged plastic based on governmental reducing actions: 15% in 2018, 40% in 2019 and 60% in 2020 comparing with prediction without the effects of reducing actions.

2.4 Ratio of mismanaged plastic waste entering the sea

To determine the ratio of plastic waste input into the sea, the amounts of plastic waste entering the sea from coastal areas of China and transported by rivers into the sea in 2017 were estimated. By sampling and conducting surveys in Wenzhou, Zhejiang Province, which is a typical coastal city in China, the sources of plastic waste released into the sea in coastal cities were found to mainly include marine fish aquaculture, coastal tourism and off-

shore fishing boats (which are weakly controlled by the MARPOL Annex V). To estimate the approximate amount of plastic waste transported by rivers into the sea in China, Huangpu River which is the last tributary of the Changjiang River before it empties to East China sea was selected. Huangpu River is a representative river into the sea due to the population density on the hydrographic net without dyke protection comparing with other rivers in China (Table 2). We used the data from the daily collection of floating garbage from the Huangpu River (Shanghai Administration Department of Afforestation and City Appearance, 2018) and population living in the area connected with the hydrographic net of Huangpu River. All coefficients in equations were obtained from field surveys and research papers.

2.4.1 Marine fish aquaculture

Marine fish aquaculture leads to the release of many plastic foam pontoons and domestic garbage from people engaged marine aquaculture entering the sea. The amount of plastic waste entering into the sea from marine fish aquaculture (A_{O1} , Mt) consists of the amounts of plastic foam pontoons, plastic mesh and domestic plastic waste generated by the people engaged marine aquaculture. A_{O1} was calculated as follows:

$$A_{O1} = S \times Y \times 25\% \times M_1 + S \times M_1 \times U \times 20\% \times 50\% + N_1 \times P_1 \times t_1 \times 100\% ,$$

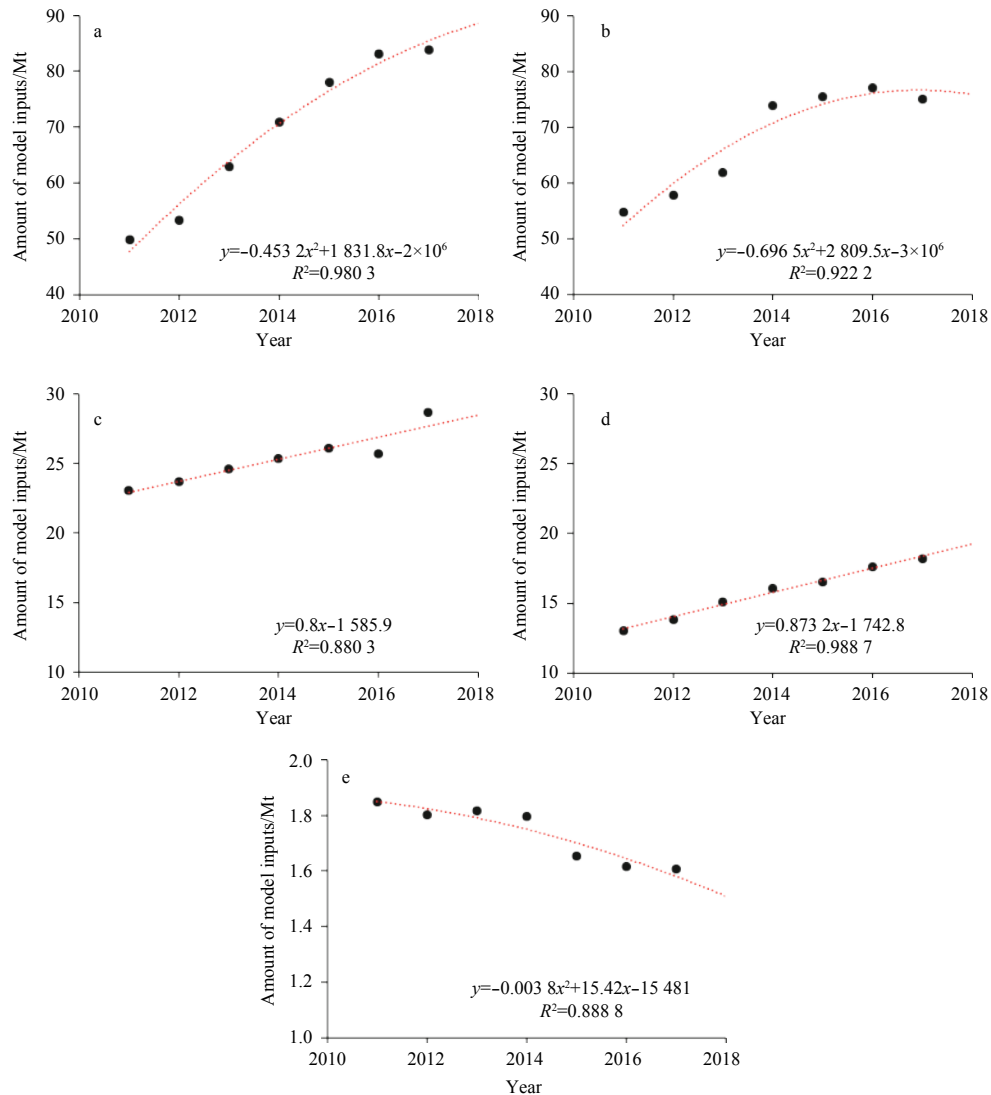

Fig. 2. Trend lines between model inputs and year. Input: production of primary plastic (a); input: production of plastic products (b); input: import of primary plastic (c); input: export of plastic products (d); input: import of plastic products (e); Mt=million tons.

where S is area of marine fish aquaculture (Ministry of Agriculture, Fisheries Bureau of the PRC, 2018). Y is usage amount of plastic foam pontoons, which is 0.75 plastic foam pontoon/ m^2 aquaculture area, each plastic foam pontoon weighs 2 kg (M_1), and 25% of damaged plastic foam pontoons will enter the sea; M_2 stands for the weight of plastic mesh per square meter is 0.8 kg, U is usage amount of plastic mesh, 5 m^2 plastic mesh/ m^2 aquaculture area, and 20% of plastic mesh will be replaced while 50% of replaced plastic mesh will enter the sea; N_1 is number of persons engaged marine fish aquaculture (Ministry of Agriculture, Fisheries Bureau of the PRC, 2018), people engaged marine aquaculture will produce 0.8 kg domestic garbage/person/day (State Council's First National Pollution Source General Survey Leading Group, 2008) and plastic weighs 1% in the domestic waste. Persons engaged marine fish aquaculture work approximately 300 days each year (t_1); by conducting field surveys, domestic garbage from small marine fish aquaculture boats without garbage collection regulations will 100% enter the sea.

2.4.2 Coastal tourism

Coastal tourism will result in plastic garbage leaving on the

beach and into the sea by waves and wind. The amount of plastic waste entering the sea from coastal tourism (A_{O2} , Mt) was calculated as follows:

$$A_{O2} = N_2 \times P_2 \times 96\% \times 26\% \times t_2 \times 10\% ,$$

where N_2 is number of coastal tourists (Ministry of Culture and Tourism of the PRC, 2018), tourists will produce 0.29 kg garbage/tourist/day (State Council's First National Pollution Source General Survey Leading Group, 2008) (P_2); non-degradable garbage weighs 96% in all garbage from tourist while plastic accounts for 26% (Kuniyal et al., 2003); 10% plastic garbage will enter the sea from coastal areas (Thompson, 2007) and coastal scenic area busy approximately 180 days a year.

2.4.3 Rivers

Using the data on daily collected floating garbage from the Shanghai Administration Department of Afforestation and City Appearance (Shanghai Administration Department of Afforestation and City Appearance, 2018), the amount of plastic waste transported by rivers to the sea (A_{O3} , Mt) was calculated as fol-

lows:

$$A_{O3} = \frac{M_3 \times 1\% + M_4 \times 25\%}{N_3} \times N_4,$$

where M_3 and M_4 are annual amount of domestic garbage from crews and floating garbage on the Huangpu River (Shanghai Administration Department of Afforestation and City Appearance, 2018), plastic accounts for 1% in domestic waste from crews and plastic waste accounts for 25% in floating garbage on the Huangpu River; N_3 and N_4 are population of the Huangpu River basin and basin of all rivers into the sea of China (Table 3, National Bureau of Statistics of the PRC, 2018).

2.4.4 Offshore fishing boats

Coefficients and data were obtained from field survey and the People’s Republic of China ministry of agriculture, fisheries bureau (Ministry of Agriculture, Fisheries Bureau of the PRC, 2018). The plastic waste generated in offshore fishing boats which include domestic waste and plastic foam boxes (A_{O4} , MT) is calculated via:

$$A_{O4} = N_5 \times P_1 \times 1\% \times t_3 \times 50\% + N \times q \times M_5,$$

where N_5 is number of crew in fishing boats (Ministry of Agriculture, Fisheries Bureau of the PRC, 2018), and crews will produce 0.8 kg domestic garbage/person/day (State Council’s First National Pollution Source General Survey Leading Group, 2008) (P_1) while plastic accounts for 1%; 50% domestic garbage may enter the sea; crew in fishing boats work approximately 180 days a year due to fishing bans and weather; N is number of offshore fishing boats and fishing boats unintentional damaged almost 30 plastic foam boxes (q) annually with each plastic foam box weights 0.5 kg (M_5).

For 2017, A_{O1} was calculated to be 0.670 7 Mt, A_{O2} was 0.012 0 Mt, A_{O3} was 0.159 1 Mt and A_{O4} was 0.003 9 Mt. The sum of A_{O1} , A_{O2} , A_{O3} and A_{O4} is considered equal to the amount of plastic waste entering the sea from China in 2017 (Table 3); therefore, the ratio of plastic waste entering the sea was 31.80%.

Wenzhou is a coastal city with a highly developed marine fishery and coastal tourism, which may lead to a large quantity of

plastic waste entering the sea from marine fish aquaculture and coastal tourism, and that the status of floating garbage collected in the Huangpu River does not represent the national average, meanwhile the sources of plastic waste enter the sea calculated in this study are not comprehensive enough, this ratio of 31.80% may be an approximation. Considering yearly fluctuations of unpredictable plastic waste volume is about 5%, we used 31.80% as a medium ratio of mismanaged plastic waste entering the seas in China, 5% downward fluctuating to 26.80% and 5% upward to 36.80% as the minimum and maximum ratios respectively to obtain a reasonable range of input of plastic waste into the sea from China.

3 Results and discussion

3.1 Fraction A of the MFA model

According to data from the CPPIA (CPPIA, 2013) and the National Bureau of Statistics of the PRC (National Bureau of Statistics of the PRC, 2018), we divided plastic products into five categories according to production type: plastic film, plastic foam, plastic synthetic leather, plastic commodities and other types of plastic (Free et al., 2014; Ma, 2018). Table 4 shows the specific information on these plastic product types.

At the end of its service life, a plastic product becomes plastic waste. Some plastic waste will be recycled, whereas the unrecycled portion will become plastic garbage. The coefficients indicated by red lines in Fig. 3 are the ratio of primary plastics made into plastic products (W_{PD}), the processing ratio of each type of plastic product (W_{Pi}), the import ratio of each type of plastic product (W_{Ii}), the scrap ratio of each type of plastic product (W_{Wi}) and the ratio of unrecycled plastic waste (W_{UR}), and these coefficients are all positively correlated with the output. The coefficients marked with blue lines are the export ratios of each type of plastic product (W_{Ei}), and these coefficients are negatively correlated with the output. By combining the positive and negative coefficients, the minimum, medium and maximum values of the output of the Fraction A in model can be determined. The inputs to Fraction A are the import of primary plastic (I_{pp}) (General Administration of Customs of the PRC, 2018), primary plastic production (Q_{pp}) (National Bureau of Statistics of the PRC, 2018), import of plastic products (I_p) (CPPIA, 2012, 2013, 2014,

Table 3. Amount of marine plastic waste input in China in 2017

Categories	Components	Amount/Mt
Marine aquaculture (A_{O1})	plastic foam pontoons	0.670 7
	plastic mesh	
	plastic garbage generated by people engaged marine aquaculture	
Coastal tourism (A_{O2})	mismanaged plastic garbage generated by the tourists	0.012 0
	Rivers (A_{O3})	
Offshore fishing boats (A_{O4})	mismanaged plastic waste generated by inhabitants living in river basins	0.159 1
	plastic foam boxes	
	domestic plastic garbage generated by the crews of offshore fishing boats	
Total		0.845 7

Table 4. Specific descriptions of the five types of plastic products considered in this study

Type	Specific items
Plastic film	agricultural, industrial and commercial plastic films; packaging and other plastic film items
Plastic foam	plastic foam boxes, plates, pipes and other plastic foam items
Plastic synthetic leather	leatherette, synthetic leather
Plastic commodities	kitchenware and sanitary ware plastic products, plastic clothing, plastic decorations and other plastic products for daily use
Other types of plastic	plastic plates, pipes, ropes, containers, components, artificial turf (except for the above plastic materials)

2015, 2016, 2017; Ma, 2018), export of plastic products (E_p) (CP-PIA, 2012, 2013, 2014, 2015, 2016, 2017; Ma, 2018) and import of plastic waste (I_w) (Feijiu.net, 2017; Jiang, 2014). The output of Fraction A is plastic garbage (Q_{UR}). Calculation method and sources of coefficients in Fraction A of MFA model are shown in Table 1.

3.2 Coefficients in the MFA model

Reliable datasets from 2011–2017 in China were used as the input. The data were processed, and model simulation tests were conducted to determine the value of each coefficient in the model. The value distributions and outliers for each coefficient are shown in Fig. 4.

It can be seen from Fig. 4 that the coefficients in the MFA model vary within certain ranges. For consistency, the ranges of the coefficients are defined as the mean±standard deviation (StDev) without outliers. For the calculation, positive coefficients are defined as the mean + StDev, and negative coefficients are

defined as the mean – StDev to get the range of model estimation.

3.3 Quality assessment of the model

Because the output of Fraction A is the amount of plastic garbage generated in China based on official statistical data and the amount of plastic waste entering the sea has not been subject to official monitoring, the quality assessment of the MFA model was performed by assessing the accuracy of Fraction A in the MFA model (Fig. 5). In this study, data on the generation of municipal domestic garbage (MOHURD, 2017a) were combined with the percentage of plastic waste in household garbage that is $11.16\% \pm 5.01\%$ (Table 5) to determine the true amount of plastic garbage generated in China.

Figure 5 indicates that: (1) the model can predict the annual amount of plastic garbage generated in China with reasonable accuracy and (2) among the maximum, medium and minimum predicted amounts of plastic garbage, the maximum predicted values deviate the least from the real values (t -test, $p=0.311$).

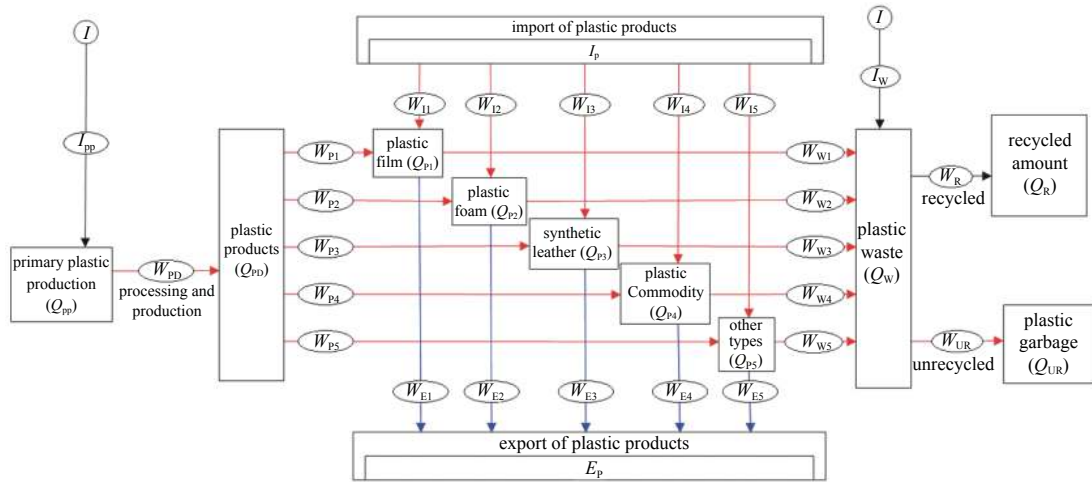

Fig. 3. Fraction A of the MFA model. W_{pi} represents processing ratio of each type of plastic product, W_{li} import ratio of each type of plastic product, W_{ei} export ratio of each type of plastic product, and W_{wi} scrap ratio of each type of plastic product. The specific descriptions of the coefficients and processes are given in Table 1.

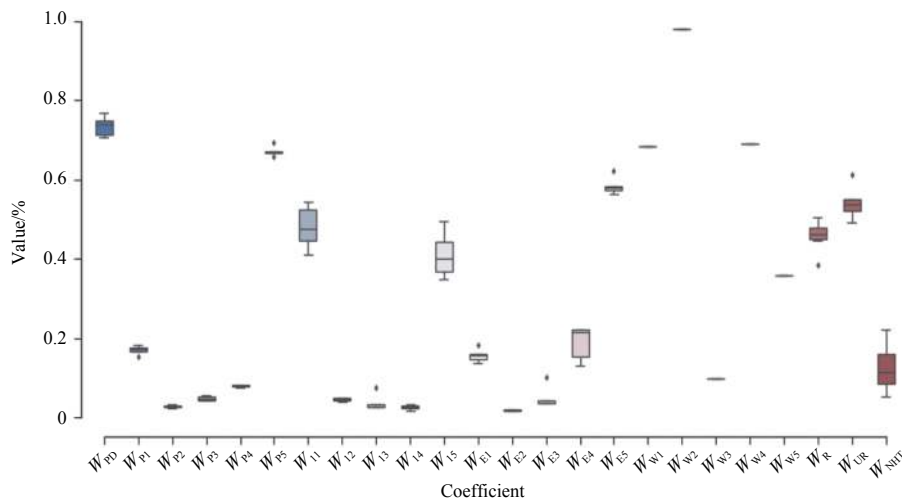

Fig. 4. Coefficient distributions of the model. The horizontal lines in the box plots from top to bottom represent the 75th percentile, median and the 25th percentile. The whiskers represent 1.5 times the range between the 25th and 75th percentiles, and the dots represent data outside this range. The dots are outliers that have been individually plotted and removed from the calculations. The specific definitions of the coefficients are shown in Table 1 and Table 2.

Therefore, the coefficients that lead to the maximum amount of plastic garbage should be chosen for use in Fraction A of the model (Table 6).

3.4 Fraction B of the MFA model

The output of Fraction A, the maximum values of plastic

garbage (Q_{UR}), will enter Fraction B (Fig. 6) of the MFA model as the input. China currently promotes the harmless treatment (HT) of domestic garbage, which includes landfill, incineration and compost treatment processes (Zhang et al., 2011).

We assumed that all plastic waste that underwent HT would remain on land because the amounts of plastic waste residues

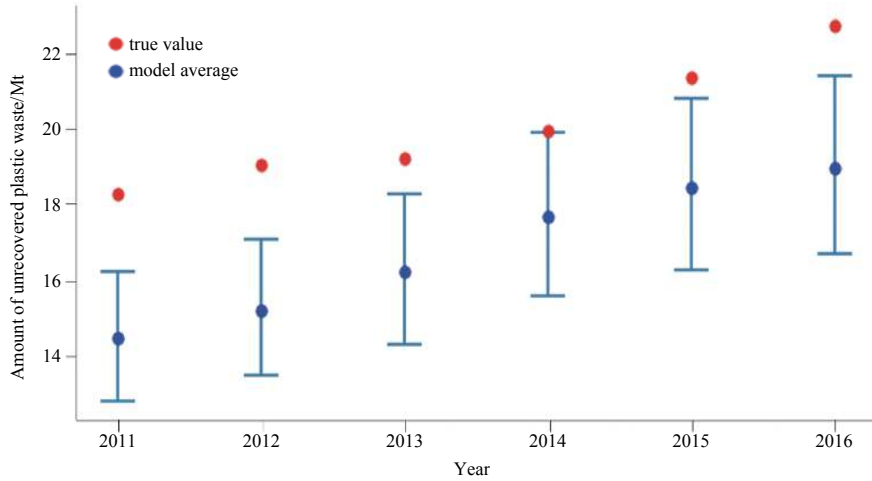

Fig. 5. Model-predicted amounts of plastic garbage versus true values. The blue dots represent the medium amounts of plastic garbage calculated from Fraction A of the model, and the red dots represent the real amounts of plastic waste generated in China. The top lines represent the predicted maximum amounts of plastic garbage, and the bottom lines represent the predicted minimum amounts of plastic garbage.

Table 5. Ratios of plastic in domestic garbage in cities of China

Regions	Cities	Plastic in domestic garbage/%	Sources	Regions	Cities	Plastic in domestic garbage/%	Sources
Eastern China ¹⁾	Beijing	19.47	Li et al. (2001)	Western China ¹⁾	Inner Mongolia	10.00	Zhang et al. (2007)
	Tianjin	17.91	Peng et al. (2014)		Chongqing	12.00	Yu et al. (2014)
	Hebei	9.10	NA ²⁾		Sichuan	15.40	Fu et al. (2014)
	Shanghai	13.98	Li et al. (2001)		Guangxi	12.40	Zhang et al. (2014)
	Jiangsu	11.20	Zhou et al. (2000)		Guizhou	2.49	Jiang and Liu (2004)
	Zhejiang	23.86	Li et al. (2001)		Yunnan	5.00	NA ²⁾
	Fujian	9.55	NA ²⁾		Tibet	11.90	Ci et al. (2007)
	Shandong	11.20	Li et al. (2001)		Shannxi	7.93	Li et al. (2001)
	Guangdong	20.15	Liu et al. (2005)		Gansu	13.00	Gou et al. (2012)
	Hainan	10.10	NA ²⁾		Ningxia	2.60	Li et al. (2000)
Central China ¹⁾	Shanxi	8.90	NA ²⁾	Qinghai	2.80	NA ²⁾	
	Anhui	10.80	NA ²⁾	Xinjiang	9.60	Chen et al. (2010)	
	Jiangxi	9.10	NA ²⁾	Northeastern China ¹⁾	Heilongjiang	4.50	NA ²⁾
	Henan	10.32	Zhang et al. (2014)		Jilin	15.00	Liu et al. (2005)
	Hubei	9.29	Li et al. (2001)		Liaoning	14.55	Ren et al. (2011)
	Hunan	11.72	NA ²⁾				

Note: ¹⁾ According to the definition of classification 3 (based on the natural geographical location) in the Ministry of Housing and Urban-Rural Development (MOHURD) yearbook (MOHURD, 2017a); NA²⁾ means no analysis in papers, determined the value according to ratio of plastic in domestic waste from cities with similar GDP and population.

Table 6. Coefficients used in Fraction A of national model

Coefficients	Value/%	Coefficients	Value/%	Coefficients	Value/%	Coefficients	Value/%
W_{PD}	76.00	W_{11}	53.30	W_{E1}	14.24	W_{W1}	68.39
W_{P1}	18.06	W_{12}	4.99	W_{E2}	1.79	W_{W2}	98.11
W_{P2}	3.21	W_{13}	3.24	W_{E3}	3.54	W_{W3}	9.81
W_{P3}	5.45	W_{14}	3.22	W_{E4}	14.69	W_{W4}	69.16
W_{P4}	8.26	W_{15}	46.74	W_{E5}	56.85	W_{W5}	36.04
W_{P5}	67.18					W_{UR}	55.08

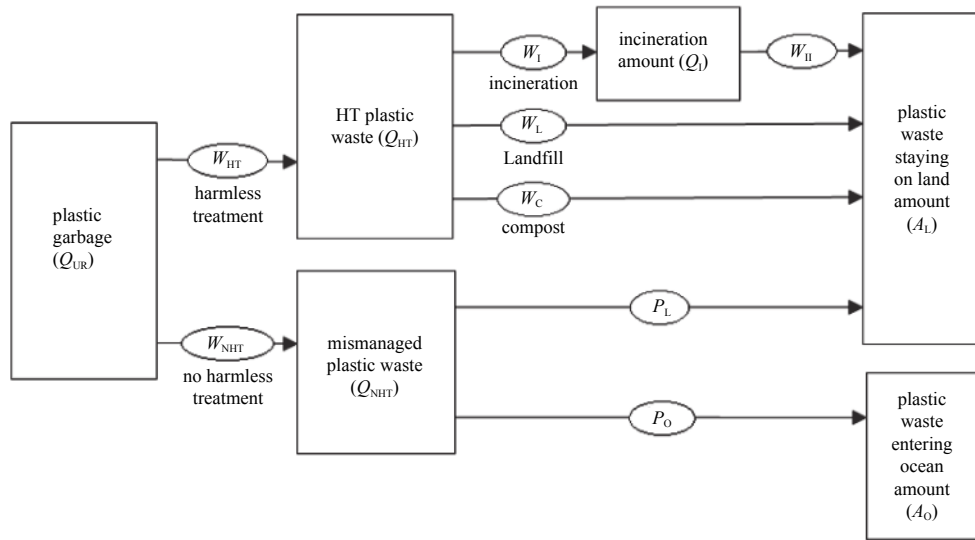

Fig. 6. Fraction B of the MFA model. HT represents harmless treatment. The specific descriptions of the coefficients and processes are given in Table 2.

from landfilling, composting and incineration that may enter the sea are negligible compared to the total amount of plastic waste that undergoes HT. Plastic garbage not subjected to HT, which include directly littered plastic waste (defined as 2%× plastic garbage (Keep America Beautiful WD, 2009)) and the percentage of plastic waste in household garbage (11.16%× domestic garbage without HT (MOHURD, 2017a)), was identified as mismanaged plastic waste. The average ratio of plastic garbage not subjected to HT and maximum values of plastic garbage from Fraction A are used in Fraction B to obtain the annual amount of plastic waste entering the sea from China. Calculation method

and sources of coefficients in Fraction B of MFA model are shown in Table 7.

3.5 Amount of plastic waste entering the sea

The annual amounts of plastic waste entering the sea from 2011 to 2020 are shown in Fig. 7.

In 2011, the amount of plastic waste entering the sea in China was 0.547 3 to 0.751 5 Mt, with an average growth rate of 4.55% each year until 2017. In 2016, the amount of plastic waste entering the seas was the highest at 0.721 9–0.991 3 Mt. Rapid decreases begin in 2017 in both Conditions 1 and 2. Due to redu-

Table 7. Coefficients in Fraction B of the MFA model

	Description	Calculation method	Mean/%	Sources
W_{HT}	ratio of plastic garbage subjected to HT	–	87.41	Ministry of Commerce of the PRC (2014, 2016, 2017); MOHURD (2017a)
W_{NHT}	ratio of plastic garbage not subjected to HT	(amount of plastic waste not subjected to HT + 2×total plastic garbage)/total plastic garbage	12.59	Keep America Beautiful WD (2009); Ministry of Commerce of the PRC (2014, 2016, 2017); MOHURD (2017a)
W_I	incineration ratio of plastic waste	amount of incinerated plastic waste/total HT of plastic waste	–	MOHURD (2017a)
W_L	landfill ratio of plastic waste	amount of landfilled plastic waste/total HT of plastic waste	–	MOHURD (2017a)
W_C	compost ratio of plastic waste	amount of composted plastic waste/total HT of plastic waste	–	MOHURD (2017a)
Q_{HT}	amount of plastic waste subjected to HT	$Q_{HT} = Q_G \times W_{HT}$		MOHURD (2017a)
Q_{NHT}	amount of mismanaged plastic waste	$Q_{NHT} = Q_G \times W_{NHT}$		MOHURD (2017a)
Q_I	amount of incinerated plastic waste	$Q_I = Q_{HT} \times W_I$		MOHURD (2017a)
A_L	amount of plastic waste remaining on land	$A_L = Q_L \times W_{II} + Q_{HT} \times W_L + Q_C + Q_{NHT} \times P_L$		
A_O	amount of plastic waste entering the sea	$A_O = Q_{NHT} \times P_O$		
W_{II}	ratio of generated incineration residue		–	Zhiyan Consulting Group (2015)
P_L	ratio of mismanaged plastic waste remaining on land		–	Section 2.4
P_O	ratio of mismanaged plastic waste entering the sea		26.80 31.80 36.80	Section 2.4

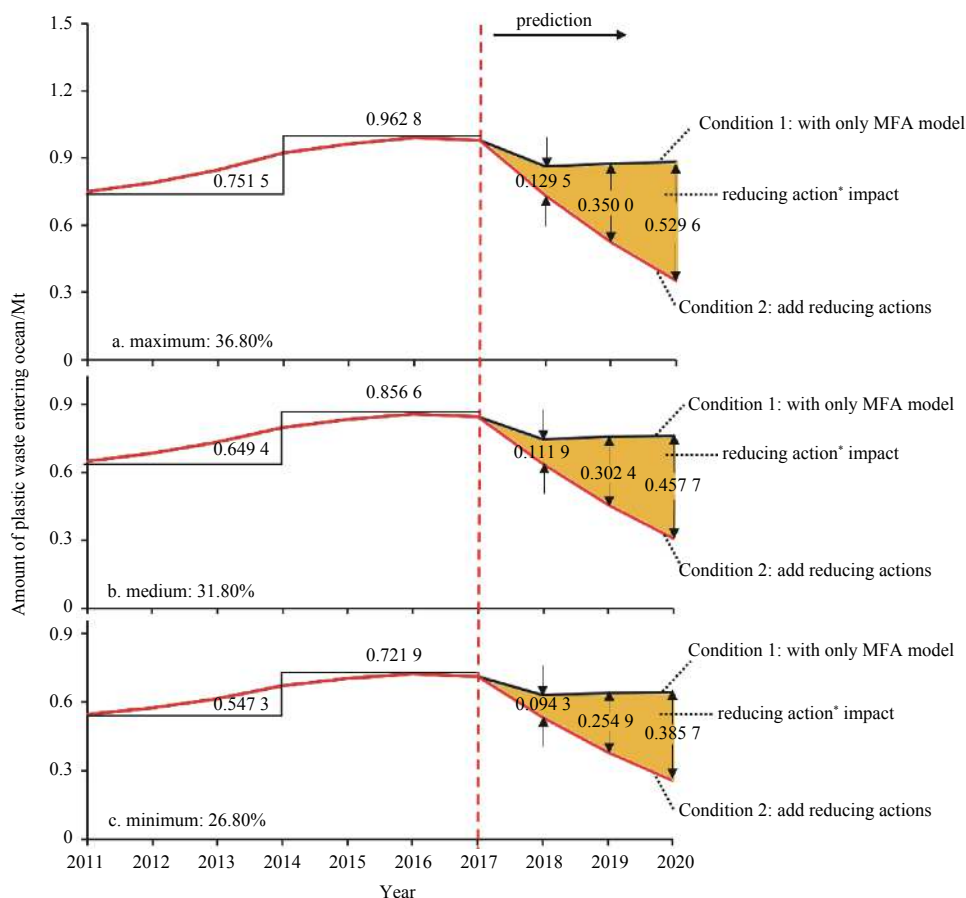

Fig. 7. Estimated and predicted annual amounts of plastic garbage entering the sea from China. Reducing action*: MOHURD and other departments comprehensively promote the management of rural domestic waste (Ministry of Commerce of the People's Republic of China and MOHURD, 2015), National Urban Ecological Protection and Construction Planning (2015–2020) (Ministry of Commerce of the PRC and Ministry of Ecology and Environment of the PRC, 2016), etc. All reducing actions are shown in Table 7. For years before 2017, we used the MFA model to estimate the amount of plastic waste entering the sea. For the predicted amounts between 2018 and 2020, the results based on only the MFA model and those considering the effects of government regulations are compared in this figure. The yellow area reflects the impact of government regulations on the amount of plastic waste entering the sea.

cing measures that strictly forbid the import of waste plastic of both industrial and domestic origin (General Office of the State Council of the PRC, 2017; Ministry of Ecology and Environment of the PRC, 2017, 2018; Ministry of Ecology and Environment of the PRC and Ministry of Commerce of the PRC, 2017; Standing Committee of the National People's Congress, 2017, 2018) and promote the classification of domestic waste (MOHURD, 2017b; National Development and Reform Commission of the PRC and MOHURD, 2017), the results of Conditions 1 and 2 exhibit quantitative differences that represent the impacts of the reducing measures (Fig. 7). For 2018, the result of Condition 2 is 0.094 3 to 0.129 5 Mt less than that of Condition 1, and for 2020, the result of Condition 1 is 0.642 8 to 0.882 7 Mt, while that of Condition 2 is 0.257 1 to 0.353 1 Mt. Table 8 shows the governmental policies, action plans and regulations related to the amount of plastic waste in China. It is noteworthy that the amount of floating plastic debris accounts for about 1% of all plastic waste.

By tracing the sources of marine plastic garbage, we found that the amount of plastic waste entering the sea is largely dependent on the effectiveness and level of HT and management of domestic waste and the collection and treatment of mismanaged plastic waste. To reduce the input of plastic waste from the human environment to the natural environment, it is necessary to

enhance the construction of urban infrastructure, promote public awareness of marine environmental issues, and establish waste management strategies and reducing measures for mismanaged plastic waste.

However, it is noteworthy that according to Table 4, the coastal fishery activities produced 0.674 6 Mt marine plastic waste in 2017, which accounts for 79.77% of the total amount of plastic waste discharged into the sea in 2017, while the amount of plastic waste discharged into the sea by rivers was 0.159 1 Mt, accounting for 18.81% of the total amount. The amount of plastic waste discharged from coastal areas was much larger than that from rivers. The reason may be that China's major rivers, such as the Yangtze River, are located in plains with a dense population, but the rivers all have flood control levees and there is little direct input of marine plastic waste. Much of the plastic waste discharged into the sea comes from poor control over the waste generated by water activities, including fisheries and shipping. The amount of plastic waste produced by coastal fisheries and aquaculture activities is huge with a high replacement rate which is about 20% every year and the effect of typhoon or other climatic factors, the total amount of plastic waste produced every year is as high as 0.674 6 Mt, which deserves close attention.

Table 8. Governmental policies and regulations related with amount of plastic waste

Legislations	Sources
Embodiment about Domestic Garbage Classification	National Development and Reform Commission of the PRC and MOHURD (2017)
Notice on Accelerating the Classification of Domestic Garbage in Key Cities	MOHURD (2017b)
Embodiment about Banning Import of Foreign Garbage into China to Promote the Reform of Solid Waste Import Management	General Office of the State Council of the PRC (2017)
Customs Law of the People's Republic of China	Standing Committee of the National People's Congress (2017)
Administration of Environmental Protection Relating to Solid Waste in the Category of Import Restriction Usable as Raw Material	Ministry of Ecology and Environment of the PRC (2017)
Catalogue for the Administration of the Import of Solid Waste	Ministry of Ecology and Environment of the PRC and Ministry of Commerce of the PRC (2017)
Measures for the Inspection, Quarantine, Supervision and Administration of Imported Solid Waste That Can Be Used as Raw Materials (2017) [Revised]	Ministry of Ecology and Environment of the PRC (2018)
Law of the People's Republic of China on Import and Export Commodity Inspection (2018 Amendment) [Effective]	Standing Committee of the National People's Congress (2018)
National Urban Ecological Protection and Construction Planning (2015–2020)	Ministry of Commerce of the PRC and Ministry of Ecology and Environment of the PRC (2016)
MOHURD and other department comprehensively promote rural domestic waste management	Ministry of Commerce of the People's Republic of China and MOHURD (2015)
Action plan of recycle agricultural film	Ministry of Agriculture of the PRC (2017)
Shanghai domestic garbage overall classification system construction action plan (2018–2020)	Shanghai Administration Department of Afforestation and City Appearance (2018)

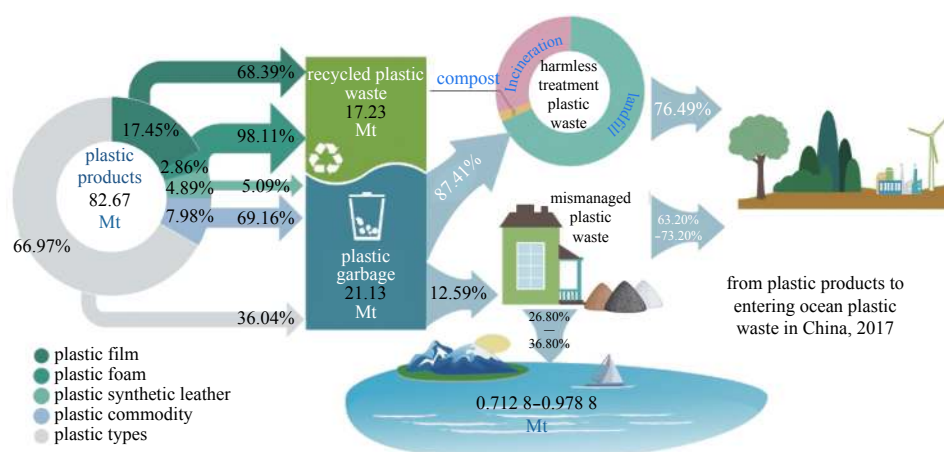
**Fig. 8.** A graphical abstract of this model.

3.6 Comparison with other studies

The amount of plastic waste predicted in this study to enter the sea in 2011 was 0.55 to 0.75 Mt, and the quantities predicted by [Jambeck et al. \(2015\)](#) in 2010 was 1.32–3.53 Mt, which is almost 2 to 5 times the annual input of China in this study.

There are two explanations for the differences between these two studies. The first is the use of different statistical methods. [Jambeck et al. \(2015\)](#) used Gross National Income (GNI) values and geographic regions to estimate the ratios of inadequately managed waste in different countries and came to the conclusion that 74% of all domestic waste in China is inadequately managed. [Jambeck et al. \(2015\)](#) estimated the mismanaged plastic waste generated by people living within 50 km of the coast, while the population of coastal cities accounts for 43% of China's total population, and regional GDP is almost 60% of the China's GDP in 2016. The characteristic of economic prosperity in coastal areas in China is part of the reason China was the biggest contributor worldwide of plastic waste enter the sea in 2010. In the present study, detailed data in each stages of plastic products were used to build an MFA model based on LCA to follow plastic

products from primary plastic to plastic waste that may be mismanaged and subsequently enter the sea. The results of this study show that only 12.59% of the plastic waste in China is mismanaged and may enter the sea. This study estimated the input of plastic waste into the sea from people living in coastal cities and plastic waste transported by rivers, and these two sources covered almost the whole emission of plastic waste from all population in China. The second explanation is the use of different data sources. The data used in the paper by [Jambeck et al. \(2015\)](#) are mainly from the World Bank ([Hoornweg et al., 2005](#)), USA. Environmental Protection Agency and NPO. And the monitoring data of municipalities in the San Francisco Bay watershed was used to evaluate the ratio of uncaptured plastic waste and thus available to enter the sea. The ratio was used in countries despite different economical levels, regulatory policies and living habits of residents near rivers and thus may cause inaccuracy estimate. Data sources in this study were more comprehensive and detailed which include annual reports of government agencies in China, market research reports, industry associations, field sampling and investigation. Data from government agencies and oth-

er sources can be tested and confirmed by each other, such as the amount of plastic products from China Plastic Processing Industry Association (CPPIA) are determined by import and production amount of primary plastic from National Bureau of Statistics, and they can verify each other's data to ensure data accuracy.

4 Conclusions

This study is the first to estimate the annual production of plastic waste in China categorized by types of plastic products. There are estimations and inferences located in coefficients and equations building stages in this study, however the prediction results of the model strongly correspond with the actual statistical data. Comparing with other studies about the emissions of plastic waste into the sea from China, the results in this study show a more detailed situation in China.

The results of this study suggest that the annual input of plastic waste into the sea from China continuously increase before 2017, the amount of plastic waste produced by coastal fishery is far greater than that from rivers. After 2017, plastic waste discharged to the sea will be reduced by China's efforts in solid waste and domestic waste management and control. With the promotion of China's ban on importing plastic waste and the construction of ecological civilization, the amount of plastic waste discharged into the sea will be greatly reduced in the future.

China plays an important role in investigating and controlling marine plastic debris. Overestimation of the amount of plastic waste entering the sea from China will ultimately lead to overestimation of the global input of marine plastic waste. Thus, studies on the quantity of marine plastic debris input should be continuously conducted until a precise amount can be determined. As for the control and management of marine plastic waste in China, it is suggested to strengthen the governance and control of plastic waste in coastal fishery aquaculture activities, which will greatly reduce the amount of marine plastic waste in China.

References

- Barnes D K A. 2002. Invasions by marine life on plastic debris. *Nature*, 416(6883): 808–809, doi: [10.1038/416808a](https://doi.org/10.1038/416808a)
- Barnes D K A. 2005. Remote islands reveal rapid rise of southern hemisphere sea debris. *The Scientific World Journal*, 5: 915–921, doi: [10.1100/tsw.2005.120](https://doi.org/10.1100/tsw.2005.120)
- Barnes D K A, Galgani F, Thompson R C, et al. 2009. Accumulation and fragmentation of plastic debris in global environments. *Philosophical Transactions of the Royal Society B: Biological Sciences*, 364(1526): 1985–1998, doi: [10.1098/rstb.2008.0205](https://doi.org/10.1098/rstb.2008.0205)
- Barnes D K A, Walters A, Gonçalves L. 2010. Macroplastics at sea around Antarctica. *Marine Environmental Research*, 70(2): 250–252, doi: [10.1016/j.marenvres.2010.05.006](https://doi.org/10.1016/j.marenvres.2010.05.006)
- Bergmann M, Klages M. 2012. Increase of litter at the Arctic deep-sea observatory HAUSGARTEN. *Marine Pollution Bulletin*, 64(12): 2734–2741, doi: [10.1016/j.marpolbul.2012.09.018](https://doi.org/10.1016/j.marpolbul.2012.09.018)
- Brunner P H, Rechberger H. 2004. Practical handbook of material flow analysis. *The International Journal of Life Cycle Assessment*, 9(5): 337–338, doi: [10.1007/BF02979426](https://doi.org/10.1007/BF02979426)
- Carpenter E J, Smith K L. 1972. Plastics on the Sargasso Sea surface. *Science*, 175(4027): 1240–1241, doi: [10.1126/science.175.4027.1240](https://doi.org/10.1126/science.175.4027.1240)
- Chen Hao, Lei Kunping, Ma Chunlan, et al. 2010. Analysis on constituent and physical and chemical characteristics of MSW in Shihezi. *Journal of Anhui Agricultural Sciences (Chinese)*, 38(23): 12666–12668
- Ci Renluobu, Duo Jie, Wu Shiyao, et al. 2007. Research of the domestic rubbish current situation of Lhasa and recycle treatment. *Tibet's Science & Technology (in Chinese)*, (9): 15–19
- Colton J B Jr, Burns B R, Knapp F D. 1974. Plastic particles in surface waters of the northwestern Atlantic. *Science*, 185(4150): 491–497, doi: [10.1126/science.185.4150.491](https://doi.org/10.1126/science.185.4150.491)
- CPPIA. 2012. China Plastics Industry (2011). *China Plastics (in Chinese)*, 26(4): 1–3
- CPPIA. 2013. China plastics industry (2012). *China Plastics (in Chinese)*, 27(5): 1–9
- CPPIA. 2014. China plastics industry (2013). *China Plastics (in Chinese)*, 28(4): 1–6
- CPPIA. 2015. China plastics industry (2014). *China Plastics (in Chinese)*, 29(5): 1–4
- CPPIA. 2016. China plastics industry (2015). *China Plastics (in Chinese)*, 30(4): 1–5
- CPPIA. 2017. China plastics industry (2016). *China Plastics (in Chinese)*, 31(5): 1–5
- Derraik J G B. 2002. The pollution of the marine environment by plastic debris: a review. *Marine Pollution Bulletin*, 44(9): 842–852, doi: [10.1016/S0025-326X\(02\)00220-5](https://doi.org/10.1016/S0025-326X(02)00220-5)
- Donohue M J, Boland R C, Sramek C M, et al. 2001. Derelict fishing gear in the northwestern Hawaiian Islands: diving surveys and debris removal in 1999 confirm threat to coral reef ecosystems. *Marine Pollution Bulletin*, 42(12): 1301–1312, doi: [10.1016/S0025-326X\(01\)00139-4](https://doi.org/10.1016/S0025-326X(01)00139-4)
- Eriksen M, Lebreton L C, Carson H S, et al. 2014. Plastic pollution in the World's Oceans: More than 5 Trillion plastic pieces weighing over 250, 000 tons afloat at sea. *PLoS One*, 9(12): e111913, doi: [10.1371/journal.pone.0111913](https://doi.org/10.1371/journal.pone.0111913)
- Fan C. 2018. Personal communication. China Scrap Plastics Association (CSPA).
- Feijiu.net. 2017. Analysis about import amount of major categories of renewable resources (in Chinese). <http://www.feijiu.net/toutiao/article/156774.html> [2017-01-20/2018-03-10]
- Fowler C W. 1987. Marine debris and northern fur seals: A case study. *Marine Pollution Bulletin*, 18(6): 326–335, doi: [10.1016/S0025-326X\(87\)80020-6](https://doi.org/10.1016/S0025-326X(87)80020-6)
- Free C M, Jensen O P, Mason S A, et al. 2014. High-levels of microplastic pollution in a large, remote, mountain lake. *Marine Pollution Bulletin*, 85(1): 156–163, doi: [10.1016/j.marpolbul.2014.06.001](https://doi.org/10.1016/j.marpolbul.2014.06.001)
- Fu Yunxia, Qiu Zhongping, Fu Chunxia, et al. 2014. Analysis of municipal solid waste composition and physicochemical properties in urban areas of Chengdu. *Sichuan Environment (in Chinese)*, 33(6): 126–129
- General Administration of Customs of the PRC. 2018. <http://www.customs.gov.cn/> (in Chinese)
- General Office of the State Council of the PRC. 2017. Embodiment about Banning Import of Foreign Garbage into China to Promote the Reform of Solid Waste Import Management (in Chinese). http://www.gov.cn/zhengce/content/2017-07/27/content_5213738.htm [2017-07-27/2018-03-10]
- Gou Jianfeng, Zeng Zhengzhong, Ji Aimin, et al. 2012. Physical composition and moisture characteristics of municipal solid waste of Lanzhou City. *Environmental Engineering (in Chinese)*, 30(6): 101–105
- Gregory M R. 2009. Environmental implications of plastic debris in marine settings--entanglement, ingestion, smothering, hangers-on, hitch-hiking and alien invasions. *Philosophical Transactions of the Royal Society B: Biological Sciences*, 364(1526): 2013–2025, doi: [10.1098/rstb.2008.0265](https://doi.org/10.1098/rstb.2008.0265)
- Hinojosa I A, Thiel M. 2009. Floating marine debris in fjords, gulfs and channels of southern Chile. *Marine Pollution Bulletin*, 58(3): 341–350, doi: [10.1016/j.marpolbul.2008.10.020](https://doi.org/10.1016/j.marpolbul.2008.10.020)
- Hoorneweg D, Lam P, Chaudhry M. 2005. Waste Management in China: Issues and Recommendations. Washington, DC: The World Bank
- Jambeck J R, Geyer R, Wilcox C, et al. 2015. Plastic waste inputs from land into the ocean. *Science*, 347(6223): 768–771, doi: [10.1126/science.1260352](https://doi.org/10.1126/science.1260352)
- Jiang Cheng. 2014. Deputy to the people's congress: We should strictly control the import of plastic waste (in Chinese). <http://www.cpcia.org.cn/html/13/20143/136308.html>

- [2014–03–14/2017–11–29]
- Jiang P, Liu Y X. 2004. Status and count measure of municipal solid waste treatment in Guizhou. *Environmental Protection Science and Technology* (in Chinese), 10(4): 1–6
- Keep America Beautiful WD. 2009. 2009 national visible litter survey and litter cost study. Mid-Atlantic Solid Waste Consultants
- Kershaw P J, Rochman C M. 2015. Sources, fate and effects of microplastics in the marine environment: part 2 of a global assessment Rep Stud GESAMP 93
- Kuniyal J C, Jain A P, Shannigrahi A S. 2003. Solid waste management in Indian Himalayan tourists' treks: a case study in and around the Valley of Flowers and Hemkund Sahib. *Waste Manage*, 23(9): 807–816, doi: [10.1016/S0956-053X\(03\)00027-8](https://doi.org/10.1016/S0956-053X(03)00027-8)
- Lebreton L, Slat B, Ferrari F, et al. 2018. Evidence that the Great Pacific Garbage Patch is rapidly accumulating plastic. *Scientific Reports*, 8: 4666, doi: [10.1038/s41598-018-22939-w](https://doi.org/10.1038/s41598-018-22939-w)
- Lebreton L, van der Zwet J, Damsteeg J W, et al. 2017. River plastic emissions to the world's oceans. *Nature Communications*, 8: 15611, doi: [10.1038/ncomms15611](https://doi.org/10.1038/ncomms15611)
- Li Xiaodong, Lu Shengyong, Xu Xu, et al. 2001. Analysis on caloric value of Chinese cities' municipal solid waste. *China Environmental Science* (in Chinese), 21(2): 156–160
- Li Youhong, Wang Fang, Chen Jue, et al. 2000. Disposal and utilization effects of municipal garbage in Yinchuan. *Agro-Environmental Protection* (in Chinese), 19(3): 145–147
- Liu Shengping, Cai Jingmin, Wu Ke, et al. 2005. Status and count measure of municipal solid waste treatment. *Journal of Hefei University (Natural Sciences)* (in Chinese), 15(4): 53–57
- Ministry of Agriculture of the PRC. 2017. Action plan of recycle agricultural film (in Chinese). http://jiuban.moa.gov.cn/zwlmlm/tzgg/tz/201705/t20170518_5612288.htm [2017–05–16/2018–01–07]
- Ministry of Agriculture, Fisheries Bureau of the PRC. 2018. China fishery statistics yearbook (2017) (in Chinese). Beijing: China Agriculture Press. <https://max.book118.com/html/2017/1010/136702944.shtm>
- Ministry of Commerce of the People's Republic of China, MOHURD. 2015. MOHURD and other department comprehensively promote rural domestic waste management. http://www.mohurd.gov.cn/wjfb/201511/t20151113_225575.html [2015–11–03/2017–12–07]
- Ministry of Commerce of the PRC. 2014. Report of China Renewable Resource Recycling Industry Development (2013). *Recycling Research*, 7: 4–7
- Ministry of Commerce of the PRC. 2016. Report of China Renewable Resource Recycling Industry Development (2016). *Recycling Research*, 9: 15–21
- Ministry of Commerce of the PRC. 2017. Report of China Renewable Resource Recycling Industry Development (2017). *Resource Recycling*, 5: 16–25
- Ministry of Commerce of the PRC, Ministry of Ecology and Environment of the PRC. 2016. National Urban Ecological Protection and Construction Planning (2015–2020) (in Chinese). http://www.mohurd.gov.cn/wjfb/201612/t20161222_230049.html [2016–12–16/2018–01–10]
- Ministry of Culture and Tourism of the PRC. 2018. China tourism statistical year book (2017) (in Chinese). Beijing: China Travel & Tourism Press. <http://www.yearbookchina.com/navibook-list-n3018051411-1.html>
- Ministry of Ecology and Environment of the PRC. 2017. Environmental Protection Regulations on Imports Restriction on Solid Wastes that Can Be Used as Raw Materials. *Tianjin Paper Making*, 43–44
- Ministry of Ecology and Environment of the PRC. 2018. Measures for the Inspection, Quarantine, Supervision and Administration of Imported Solid Waste That Can Be Used as Raw Materials (in Chinese). http://www.aqsiq.gov.cn/xxgk_13386/jlgg_12538/zjl/2017/201712/t20171218_509062.htm [2017–12–18/2018–02–10]
- Ministry of Ecology and Environment of the PRC, Ministry of Commerce of the PRC. 2017. Managed catalogues of imported waste (in Chinese). http://www.mee.gov.cn/gkml/sthjbgw/sthjbgg/201804/t20180419_434911.htm [2018–04–19/2018–05–25]
- MOHURD. 2017a. China urban-rural construction statistical year book. 2011–2016 (Chinese). Beijing: China Planning Press. <http://www.mohurd.gov.cn/xytj/tjzjxxytjgb/jstjnj/index.html> [2016–02–02/2018–02–05]
- MOHURD. 2017b. Notice on Accelerating the Classification of Domestic Garbage in Key Cities. http://www.mohurd.gov.cn/wjfb/201801/t20180103_234625.html [2017–12–10/2018–03–10]
- Morishige C, Donohue M J, Flint E, et al. 2007. Factors affecting marine debris deposition at French Frigate Shoals, Northwestern Hawaiian Islands Marine National Monument, 1990–2006. *Marine Pollution Bulletin*, 54(8): 1162–1169, doi: [10.1016/j.marpolbul.2007.04.014](https://doi.org/10.1016/j.marpolbul.2007.04.014)
- National Bureau of Statistics of the PRC. 2018. National Bureau of Statistics of China. <http://www.stats.gov.cn/tjsj/ndsj/2017/indexch.htm> [2017–10–12/2018–03–10]
- National Development and Reform Commission of the PRC. 2013. Annual report on china resources comprehensive utilization (2012). *China Resources Comprehensive Utilization* (in Chinese), 31(4): 6–12
- National Development and Reform Commission of the PRC, MOHURD. 2017. Embodiment about Domestic Garbage Classification (in Chinese). <http://www.ndrc.gov.cn/zcfb/zcfbqt/201703/W020170331310014947378.pdf> [2017–03–30/2018–06–17]
- Peng Weiguo, He Junbao, Yao Qingjun, et al. 2014. Physical compositions and influence factors of municipal domestic Waste in Tianjin. *Environmental Sanitation Engineering* (in Chinese), 22(3): 12–14
- Ren Wanxia, Geng Yong, Xue Bing. 2011. Emission and generation forecasting of municipal solid waste in Shenyang. *Environmental Science & Technology* (in Chinese), 34(9): 105–108
- Ryan P G. 2013. A simple technique for counting marine debris at sea reveals steep litter gradients between the Straits of Malacca and the Bay of Bengal. *Marine Pollution Bulletin*, 69(1–2): 128–136
- Schmidt C, Krauth T, Wagner S. 2017. Export of plastic debris by rivers into the sea. *Environmental Science & Technology*, 51(21): 12246–12253
- Shanghai Administration Department of Afforestation and City Appearance. 2018. <http://lhsh.sh.gov.cn/> (in Chinese)
- Shanghai Administration Department of Afforestation and City Appearance. 2018. Shanghai domestic garbage overall classification system construction action plan (2018–2020) (in Chinese). <http://www.shanghai.gov.cn/nw2/nw2314/nw2315/nw5827/u21aw1304805.html> [2018–04–22/2018–05–10]
- Standing Committee of the National People's Congress. 2017. Customs Law of People's Republic of China (in Chinese). <http://www.customs.gov.cn/customs/302249/302266/302267/1880958/index.html> [1987–07–01/2018–03–10]
- Standing Committee of the National People's Congress. 2018. Law of the People's Republic of China on Import and Export Commodity Inspection (in Chinese). <http://www.safehoo.com/item/1525571.aspx> [1989–02–21/2018–06–11]
- State Council's First National Pollution Source General Survey Leading Group. 2008. The first national pollution source general survey manual of urban generation and emission coefficients. Beijing: Beijing Science & Technology Press
- The Ministry of Water Resources of the PRC. 2017. China River Sediment Bulletin (2016) (in Chinese). Beijing: China Water & Power Press. <http://www.mwr.gov.cn/sj/tjgb/zghlnsgb/201709/P020170908337244537608.pdf>
- Thompson R C. 2007. Plastic debris in the marine environment: Consequences and solutions. *Marine Nature Conservation in Europe*. Stralsund, Germany: Federal Agency for Nature Conservation, 107–115
- Van Eygen E, Feketitsch J, Laner D, et al. 2017. Comprehensive analysis and quantification of national plastic flows: The case of Austria. *Resources, Conservation and Recycling*, 117: 183–194, doi: [10.1016/j.resconrec.2016.10.017](https://doi.org/10.1016/j.resconrec.2016.10.017)
- Wright S L, Thompson R C, Galloway T S. 2013. The physical impacts of microplastics on marine organisms: a review. *Environment-*

- al Pollution, 178: 483–492, doi: [10.1016/j.envpol.2013.02.031](https://doi.org/10.1016/j.envpol.2013.02.031)
- Yu Benhong, Xu Hongdeng, Huang Wanjin. 2014. Construction plan of domestic waste collection and transportation system in villages and towns at the upper reaches of the Yangtze River: Taking Wanzhou District, Chongqing City as the example. *Environmental Sanitation Engineering* (in Chinese), 22(4): 45–47
- Ma. 2018. Personal communication. China Plastics Processing Industry Association (CPPIA)
- Zhang Xuejun, Yun Xia, Song Hongwei. 2007. Urban living garbage disposal status and measures of resource optimization in Inner Mongolia. *Inner Mongolian Environmental Sciences* (in Chinese), 19(2): 26–28
- Zhang Yingmin, Shang Xiaobo, Li Kaiming, et al. 2011. Technologies status and management strategies of municipal solid waste disposal in China. *Ecology and Environment* (in Chinese), 20(2): 389–396
- Zhang Zhi, He Jingying, Hou Xiaohui. 2014. Problems and strategies of municipal domestic waste treatment in Zhengzhou. *Environmental Sanitation Engineering* (in Chinese), 22(5): 54–55
- Zhiyan Consulting Group. 2015. Research and Consultation Report of Panorama Survey and Development Strategy on China Waste Incineration Power Equipment Industry during 2015–2020 (in Chinese). <http://www.ibaogao.com/baogao/030415E5H015.html> [2015-03-04/2018-01-05]
- Zhong Jin Qi Xin Beijing International Information Consultation Co. L. 2018. Import & Export data of plastic products
- Zhou Wen, Dong Yawen, Fang Binbin. 2000. Contrast study of municipal solid waste and their disposal in Shanghai, Nanjing and Shenzhen. *Environmental Pollution and Control* (in Chinese), 22(3): 30–32